



VERRO SERIES: VTF-451S

Split Pan Turbo Fryer

Project: _____ Item: _____



VTF-451S

Standard Features:

- AISI 304 Grade Stainless Steel
- Stainless steel constructed pan with center cool zone – 2mm Thick
- Efficient dual multi-jet target burner
- +/- 3°C temperature recovery differential
- Dual over-temperature safety cut-out switches
- 13.5L oil capacity per section
- Flame failure fitted as standard
- Complete with baskets, fish plates and night covers
- Front access to all components makes service easy
- Pan Dimensions: 415mm L x 150mm W x 80mm H (Height is measured from the base plate to the oil level mark)
- 36 Month Warranty

Options:

- Natural or LP Gas
- Non-swivel rear castors

Specifications:

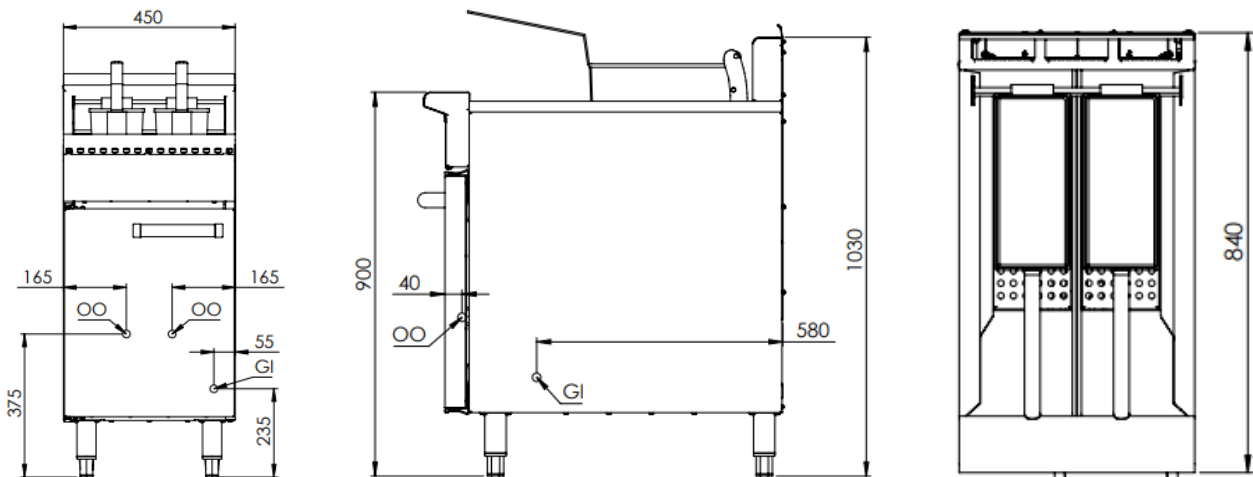

MODEL	LENGTH (mm)	DEPTH (mm)	HEIGHT (mm)	GAS CONSUMPTION (Mj/h)	
				NG	LPG
VTF-451S	450	840	1030	76	76

Connections:

GAS (GI) (BSP)	OIL OUTLET (OO) (BSP)	SUPPLY PRESSURE (kPa)	
		NG	LPG
¾" (M)	1" (F)	1.0	2.6

- Combination control valve with inbuilt regulator is supplied within the unit
- **Must** be installed by an authorised installer in accordance to **AS/NZS5601.01**

Due to ongoing Product Development, Product Improvement and Research, B+S Commercial Kitchens reserves the right to alter specification without notice.

Approval Number: GMK 10683



B+S Commercial Kitchens
57 Plateau Road Reservoir VIC 3073 Australia | +61 3 9469 4754
info@bscommercialkitchens.com | www.bscommercialkitchens.com

