

MC Series Modular Dice Ice Machines – up to 706kg

MC 1448 MA Dice cube 10g, 22mm x 22mm x 22mm

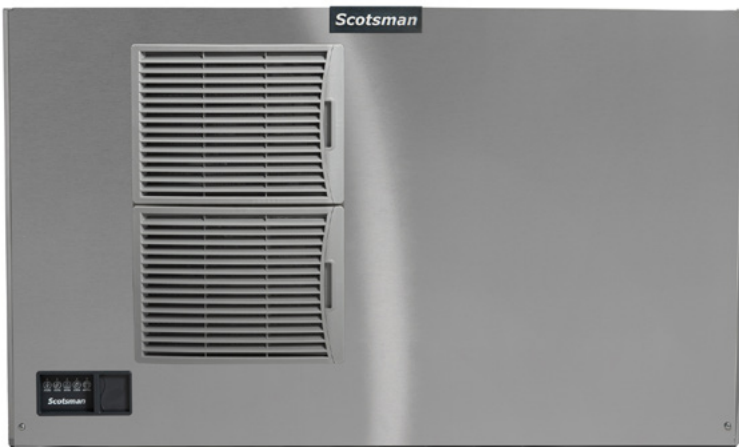

Dice cube 10 g
W 22 x D 22 x H 22 mm



Note: Ice production rate is measured with the water temperature at 10°C and an ambient temperature of 21°C.

- Up to 706kg daily production rate
- Head only ice maker - requires a separate storage bin to store the ice produced
- Air cooled version
- Vertical evaporator spray-system technology
- Agion Technology resists the growth of microbes and the development of unpleasant odours
- One-touch cleaning system
- Electronic control
- Water sense adaptive purge control: saves water by adjusting water usage when is needed
- Simple, reliable electromechanic controls
- Resistant stainless steel exterior
- Easy access front condenser air filter
- External indicator lights to show operation status and maintenance alert
- Includes removable air filter, water and drain hose

Recommended storage bins

- NB 948 – 406kg storage capacity
- UBH 1100 – Upright storage bin with 553kg storage capacity

MC Series Modular Dice Ice Machines – up to 706kg

MC 1448 MA

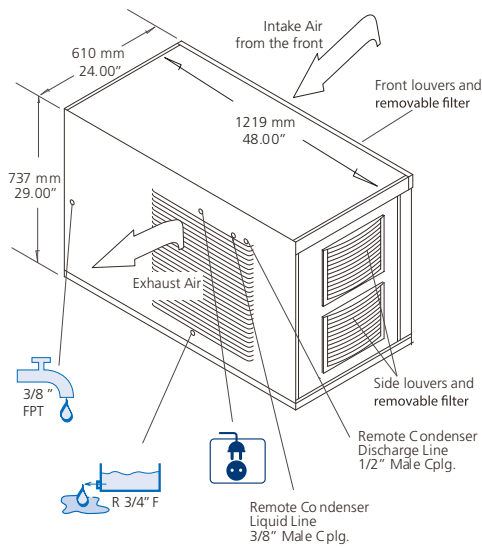

UNIT OF MEASUREMENT: mm

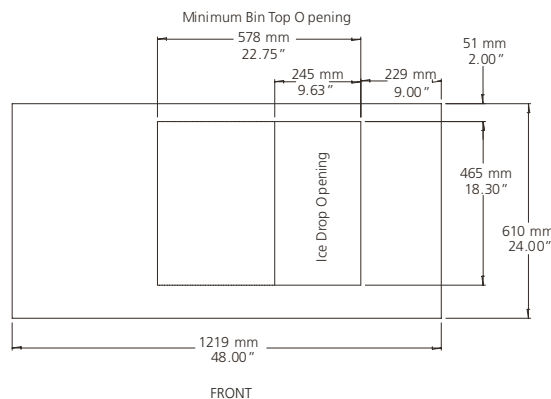

moffat.com.au

Australia
Moffat Pty Limited
Victoria/Tasmania
740 Springvale Road
Mulgrave, Victoria 3170
Telephone 03-9518 3888
Facsimile 03-9518 3833
vsales@moffat.com.au

New South Wales
Telephone 02-8833 4111
nswsales@moffat.com.au

South Australia
Telephone 03-9518 3888
vsales@moffat.com.au

Queensland
Telephone 07-3630 8600
qldsales@moffat.com.au

Western Australia
Telephone 08-9413 2400
wasales@moffat.com.au

Ice production per 24 hours

Ambient temperature / Water temperature

10°C / 10°C	21°C / 10°C	32°C / 21°C
732	706	589

Dimensions

Width: 1219mm
Depth: 610mm
Height: 737mm
Nett weight: 150kg
Packed weight: 157kg

Water consumption

Air cooled version: 26 litres per hour

Electrical rating

Air cooled version: 230-240V, 1P+N+E, 50Hz, 2430W,
30A cordset supplied
No. Circuit wire: 3
Compressor: 2280W
Energy consumption: 4.25kW/24hr

Refrigerant type

R404A

Installation distance from wall

Rear 100mm
Left side 150mm
Operating requirement air temperature 10-43°C

Water connection requirements

Inlet connection: R 3/8"
Cold water: 5-38°C
Pressure: 100-500kPa
Water outlet connection: Ø 3/4"

Important Notice:

Models and specifications are subject to change without notice. This spec sheet is meant for commercial purpose only. For technical documentation please refer to our service manuals.



© Copyright Moffat Ltd
AU.SM.2301