

**914mm WIDE RESTAURANT SERIES
CHAR BROILER**

The Garland Heavy Duty Restaurant Series is a commercial range that has been engineered for unmatched performance and durability.

Garland's cast-iron burners combine speed with precision and even heat distribution to improve efficiency and control.

Featuring stainless steel construction with a large front 127mm 'plate rail' and backguard that matches the other Restaurant Series units giving a sleek clean finish.

Cast-iron burners for every 152mm section and heavy duty ceramic briquettes sitting on horizontal bars distribute heat evenly. Protected individual pilot lights, piezo spark ignition and flame failure as standard. Large 584mm deep removable dual sided broiling grates (13mm rounded bar or diamond fine pattern). Exclusive lift-off hopper. Comes with Set of 4 legs for countertop mounting. Large easy-to-use hi-lo control knobs sit flush to the 'plate rail' and the unit can sit on top of the optional stainless steel stand with storage shelf.



GF24-BRL pictured on MS-G24B Stand

OPTIONAL FEATURES

- Stainless steel stand with shelf and adjustable feet - MS-G36B
- Swivel Fixed Height Castors for stand - legs must be shortened by 100mm - MS-CSTR (non brake), MS-CSTRB (brake)
- Flexible gas hose with quick disconnect and restraining kit - 432018-1200HK

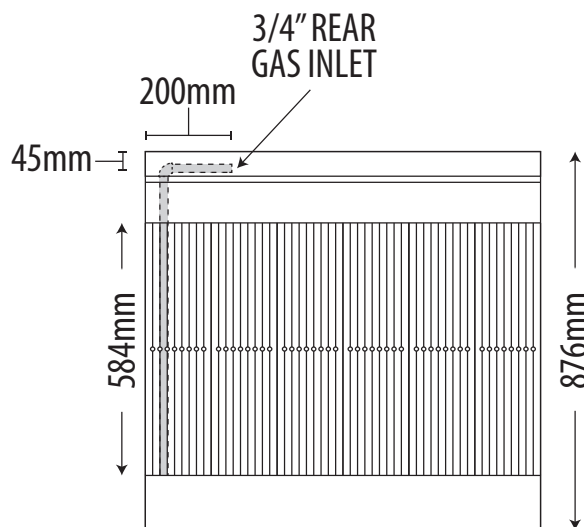
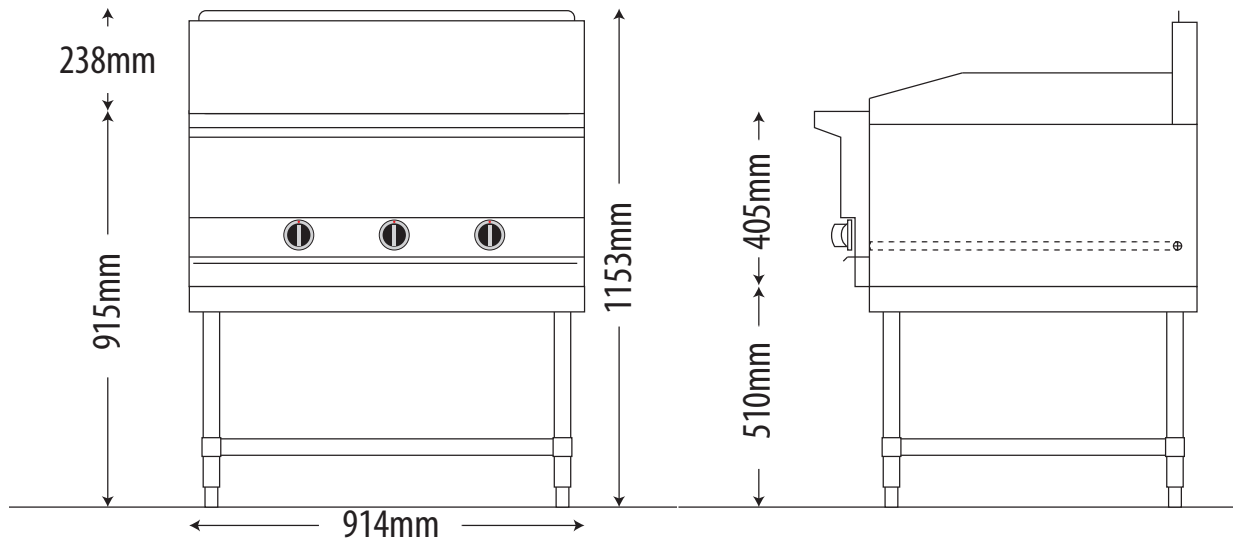
DIMENSIONS

External Dimension: 914W x 876D x 1153H (with stand) mm

Working height : 915mm

Combustible wall clearance: Side: 152mm, Rear: 152mm

TECHNICAL DATA

Gas Type: Natural or Propane

Total Output:	Natural 96MJ	Propane 96MJ
---------------	-----------------	-----------------

Burner Ratings: Open Burner	Natural 16MJ	Propane 16MJ
--------------------------------	-----------------	-----------------

Gas Connection: 3/4"

SHIPPING DATA

Shipping weight: 150kg

Shipping Dimensions: 1050W x 1050D x 1017H mm

AGA APPROVAL NUMBER

AGA 7455 G

SPECIFICATIONS ARE SUBJECT TO CHANGE WITHOUT NOTICE.