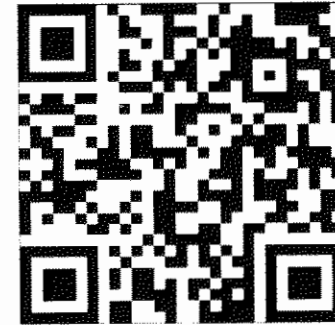

LA CARIMALI

GLOW

User Manual

REGISTERING THE PRODUCT - ACTIVATING THE WARRANTYPRODUCT REGISTRATION
WARRANTY ACTIVATIONREGISTRAZIONE PRODOTTO
ATTIVAZIONE GARANZIA

Goods are guaranteed by law (Italian Legislative Decree 24/2002) against any manufacturing defects for a period of 12 months from the date of delivery of the Carimali product.

Our customers can exploit the "Product registration" procedure within 6 months from the billing by Carimali therefore extending the validity of the Warranty for another 6 months, with respect to the date of billing. After 6 months from the date of billing, if the product has not yet been registered, the activation of the warranty shall be deemed activated from the date of billing.

CONTENT

1. INTRODUCTION	2	7. PROGRAMMING	23
1.1 Identification data of the manufacturer	2	7.1 Programming doses	23
1.2 Recipients	2	7.2 Reading and resetting counters	24
1.3 Purpose of this manual	3	7.3 Editing parameters	25
2. SYMBOLS DESCRIPTION	3	8. CLEANING	28
3. DESCRIPTION OF THE MACHINE	4	8.1 Non-ordinary maintenance and service operation	28
3.1 General	4	8.2 Cleaning frequency table	28
3.2 Keypad	5	8.3 Display cleaning	29
3.3 Machine identification data and name plates	5	8.4 Cleaning of the machine surface	29
3.4 Dimensional drawing	6	8.5 Wand cleaning	29
3.5 Table of technical data	7	8.6 Coffee group cleaning	30
4. SAFETY PRECAUTIONS	8	8.7 Periodic boiler emptying	31
4.1 Intended use	8	8.8 Cleaning of the sprayhead, filter holder and filter	32
4.2 General warnings	9	9. ERROR MESSAGES	35
4.3 Residual risk	11	10. LED LIGHTS	36
4.4 Storage	11		
4.5 Unpacking	11		
4.6 Positioning	12		
4.7 Installation	12		
4.8 Maintenance	12		
4.9 Cleaning	13		
4.10 Disposal	13		
5. INSTALLATION	14		
5.1 Positioning of the machine	14		
5.2 Water mains connection	14		
5.3 Power main connection	16		
5.4 Power ON	17		
5.5 Boiler emptying at first start-up	19		
5.6 Circuit flushing at the first start-up	20		
6. USE	20		
6.1 Coffee dispensing	20		
6.2 Steam dispensing	22		
6.3 Hot water dispensing	22		
6.4 Power OFF	22		

1. INTRODUCTION

1.1 IDENTIFICATION DATA OF THE MANUFACTURER

THE MANUFACTURER:
CARIMALI S.p.A.

OPERATIONAL FACILITIES:

CARIMALI S.p.A.
Via Industriale, 1- -24040 Chignolo d'Isola (BG) Italy - Tel: +39 035 4949555
info@carimali.com - carimali.com

CARIMALI BUSINESS UNIT ITALIA
Via De Gasperi 17/19, 20020 Lainate (MI) Italy - Tel: +39 02 9374740
italia@carimali.com - carimalitalia.com

CARIMALI CHINA
1801 Pangjin RD, Building T2, Wujiang Suzhou China 215200 - Tel: +86 0512-63199566
suzhou.catering@carimali.com - carimalichina.com
AFTER SALES SERVICE:
service@carimali.com
All machine manuals are available for download in the reserved area in:
<https://aftersales.carimali.com/it>

1.2 RECIPIENTS



USER

Person assigned to basic machine operation and cleaning. This manual is an essential component for using the machine.

It is intended for the end user and contains instructions and information on how to use the machine safely. However, reading this manual does not exempt the recipients from reading, carefully and in full, all the instructions provided together with the machine and available on the manufacturer's official website <https://carimali.com/>, after registering in the customer area.

1.3 PURPOSE OF THIS MANUAL

The present manual was drafted to provide the user with all the information necessary to use the machine correctly, highlighting the residual risks and also those deriving from an incorrect use. This manual is integral part of the machine it is supplied with and must be carefully stored. As this manual refers to different models, the pictures contained in it are to be considered purely indicative. Some of them may show details or particulars which are slightly different from those of the product in your possession, without however changing the essential information. The manufacturer reserves the right to update this manual without prior notice should it be deemed necessary.

2. SYMBOLS DESCRIPTION



HAZARD

Indicates situations of severe danger that can seriously endanger the health and safety of individuals.



WARNING

Indicates the need to take appropriate action so as not to endanger the health and safety of individuals and not to cause damage to the machine or the environment.



IMPORTANT

Indicates technical information of particular importance that should not be ignored.

3. DESCRIPTION OF THE MACHINE

3.1 GENERAL

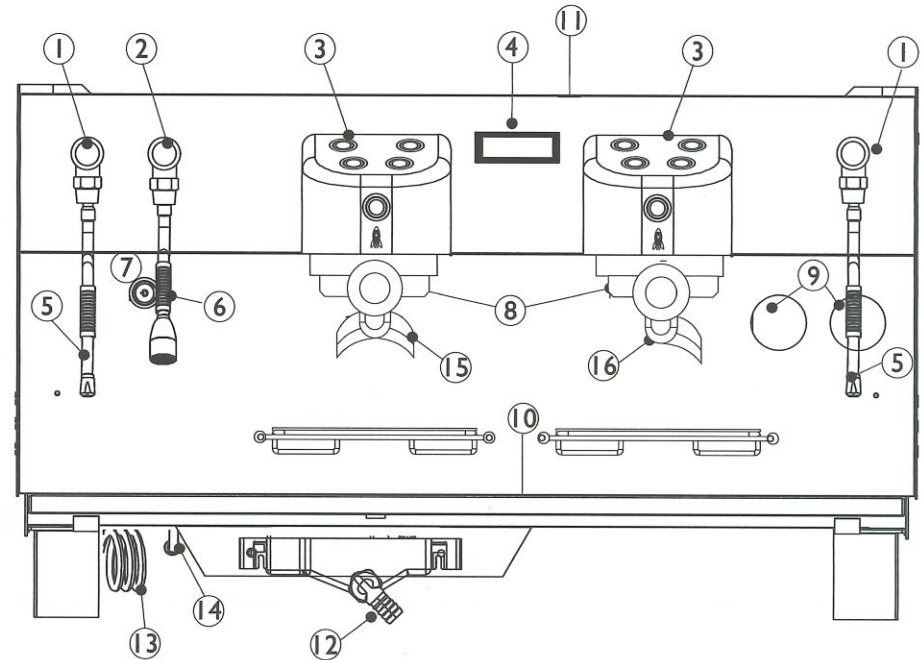

1	Steam lever	7	ON/OFF switch	13	Power cord
2	Hot water lever	8	Coffee group	14	Water inlet
3	Brewing buttons	9	Pressure gauges	15	Double portafilter
4	Display	10	Deep tray	16	Single portafilter
5	Steam wand	11	Cup warmer		
6	Hot water wand	12	Water outlet		

3.2 KEYPAD

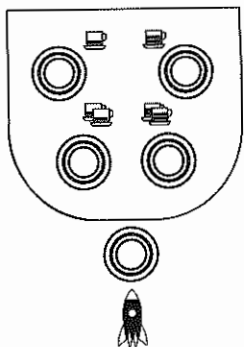

	Short Espresso
	Long Espresso
	Double short Espresso
	Double long Espresso
	Continuous delivery

3.3 MACHINE IDENTIFICATION DATA AND NAMEPLATES

Each machine is identified by a CE plate placed under the base on which the reference data of the same are indelibly written. These reference data must always be provided when communicating with the manufacturer or service centers.

IMPORTANT The nameplate must not be removed for any reason, under penalty of forfeiture of the guarantee and the unavailability of spare parts, which cannot be identified.

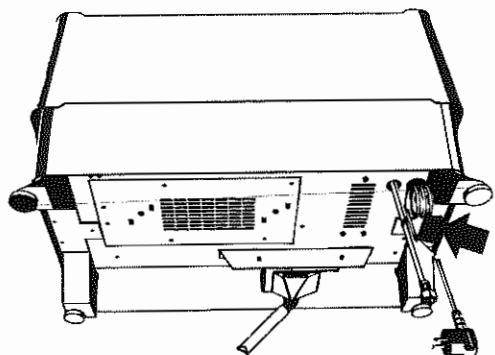

LA CARIMALI 04/24

Model: GLOW **1**

Input: 220-240V **2** 50-60 Hz

Nominal power: 3100W **3**

S/N CNXXXX **4**

Boiler press.: P_n = 1.3 **5** bar = 0.13 MPa

Inlet water press.: **6** 0.10 MPa / max 0.60 MPa

www.carimali.com
Section B of Building T2, No. 1801, Pangjin RD.,
Wujiang, Suzhou, Jiangsu, China, 215200

Made in China

1	Model	4	Serial number
2	Input voltage	5	Nominal steam boiler pressure
3	Nominal power	6	Inlet water pressure

3.4 DIMENSIONAL DRAWING

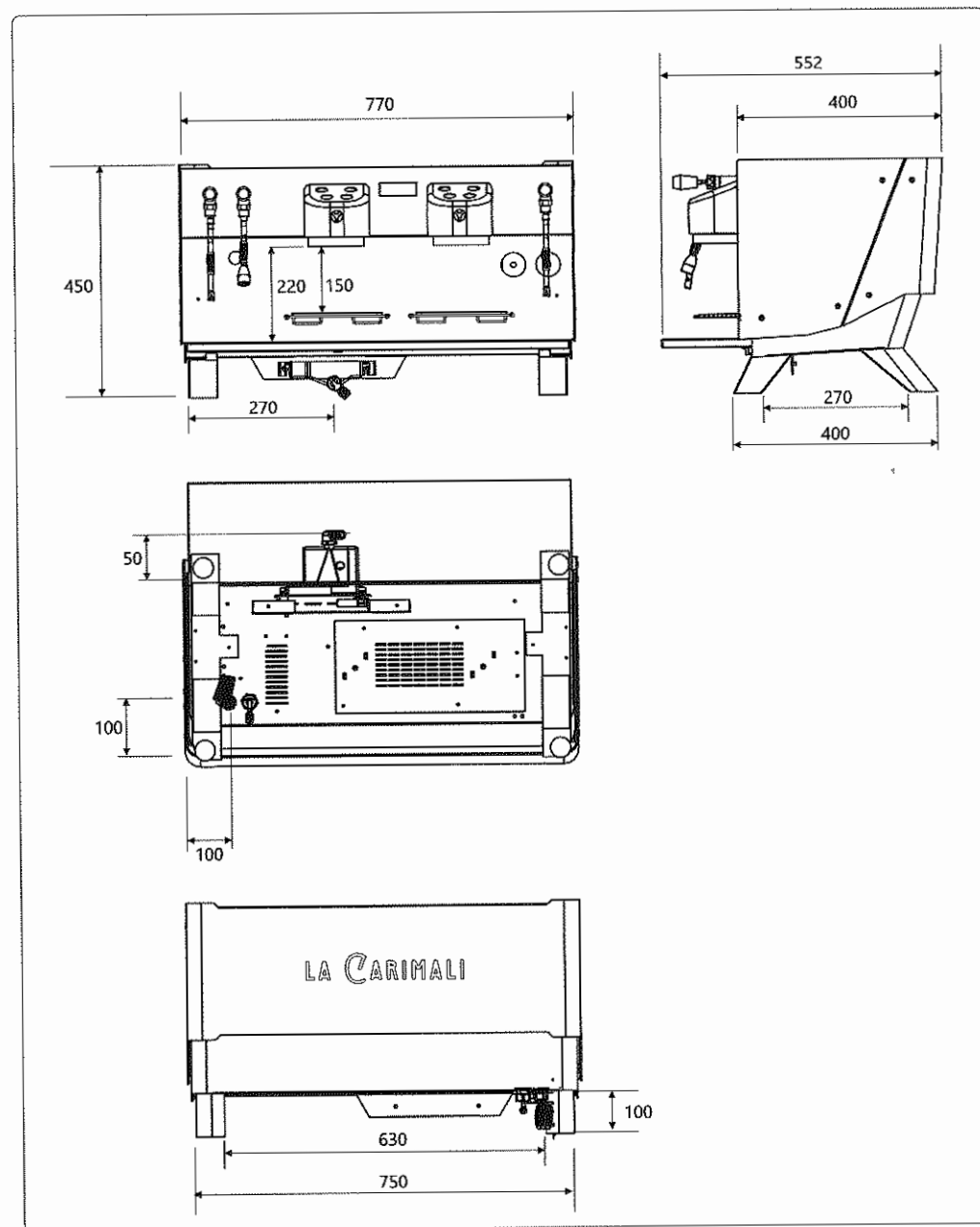

3.5 TABLE OF TECHNICAL DATA

Description	1 GROUP	2 GROUPS
DIMENSIONS		770x552xH450
NET WEIGHT		55
HEIGHT WORKING AREA (with portafilter)		140
NO. OF SELECTION BUTTONS		5
DISPLAY		YES
BOILER CAPACITY		11l
BOILER HEATING ELEMENT		2800W
PROTECTION OF BOILER HEATING		Resettable double thermostat
GAUGE		1 Double scale
VOLTAGE SUPPLY		Single phase 220-240V 50-60Hz

4. SAFETY PRECAUTIONS

Thoroughly read the instructions contained in this booklet because it gives important information regarding safety for installation, use and maintenance.

Keep this booklet in a safe and accessible place for further consultation.

4.1 INTENDED USE

GLOW is a professional machine designed and built only and exclusively to dispense:

- Coffee
- Cappuccino
- Milk
- Steam
- Hot water

The machine is intended for professional use, such as:

- Refreshment areas in shops
- Refreshment areas in offices
- Refreshment areas in other environments
- Holiday farms
- Hotel / Motels
- Bed & Breakfast



WARNING

The machine is not intended for outdoor use.



IMPORTANT

Any liability that may arise from the incorrect use of the machine, or in any case from a use that is different from the instructions given in this manual, shall not be accepted, in particular if the instructions for use, maintenance and cleaning of the machine are not observed, which may lead to poor hygienic conditions.

The use of products/materials other than those specified by the manufacturer, which may result in damage to the machine and in situations of danger for the user and/or persons in the vicinity of the machine, shall be considered incorrect and improper.



IMPORTANT

Any improper use automatically invalidates the warranty and exempts the manufacturer from any liability for damage to persons, property or animals.

4.2 GENERAL WARNINGS

The use of any electric appliance implies the observance of some fundamental rules.



The appliance should be installed from a professional skilled technician with knowledge about electrical connections and Hydraulic connections.
In case of any doubt please contact the authorized distributor.



Do not touch the appliance with your hands or feet wet or damp Do not pull the power cord to disconnect the plug from the power socket Do not leave the appliance exposed to the weather (rain, sun, frost) Do not let children or untrained persons use the appliance.



Before carrying out any cleaning and maintenance, disconnect the appliance from the power supply, pulling the plug from the power socket and turning off the main switch.



In case of failure or malfunction turn the machine off and do not attempt to carry out any repairs or direct operations on the machine.
All repairs must be carried out in an authorized service centre, using original spare parts only



If this machine is no longer used we recommend that it is made inoperative by disconnecting the cable from the power supply, and all potentially dangerous parts are made harmless, especially to protect children who might use the machine for their games.

Access to the service areas is restricted to those persons with the relevant practical experience, especially in terms of safety and hygiene.

- The appliance must be installed only in places where it can be checked by skilled personnel.
- The machine can only be used by children aged from 8 years and above and persons with reduced physical, sensory or mental capabilities or lack of experience and knowledge, if they are supervised or have been instructed on the safe use of the equipment and understand the hazards involved.
- Children are not allowed to play with the device or to carry out cleaning and maintenance operations without the supervision of trained personnel.
- Do not use adapters, multiple sockets and extension cords.
- Do not pull the power cord to unplug the machine from the electric socket, disconnect the plug directly from the socket.
- Never immerse the machine in water.
- Do not expose the machine to weather conditions (sun, rain, etc.).
- Avoid direct contact with water jets or other liquids also when cleaning the machine.
- Do not obstruct the openings or slots for ventilation or heat dissipation and do not insert water or any kind of liquid.
- Do not leave flammable objects or materials in the vicinity of the machine.
- In emergencies such as fire outbreaks, strange noises or overheating, unplug the appliance immediately and contact the Service Centre.
- Do not modify any parts of the machine under any circumstances; the manufacturer disclaims all liability should any malfunctions occur caused by failure to comply with the above. Submit any modification requests directly to the Manufacturer.
- Never use the machine with faulty or disabled safety devices.
- Never use the machine with electrical jumpers and/or mechanical means that disconnect machine parts/supplies.
- It is strictly prohibited to operate the machine without all fixed and/or removable guards in place.
- In case of faults caused by failure to observe the above, the Manufacturer declines all liability for damages caused by non-compliance with the aforesaid provisions.

4.3 RESIDUAL RISKS

Risk of scalding: avoid accidental contact with the hot water wand, with hot beverages and hot parts of the machine.

Risk of electrocution: never use machines in need of maintenance, with damaged power cables or incorrect electrical connections;

- never touch the machine or power sockets when hands or other body parts are wet;
- never immerse the machine in water or other liquids.



The connection of the single-phase versions of this coffee machine is permitted only in areas that have an electrical system that guarantees a reference impedance adequate to the current consumption of the appliance ($Z_{max} = 0.06 \text{ Ohms}$).

4.4 STORAGE

In case of extended storage, the room temperature must not drop below 2 °C. During subsequent use, do not switch the machine on before having reconditioned it for at least 1 hour at a suitable room temperature

4.5 UNPACKING



All packing materials (plastic wrapping, polystyrene, etc.) are potentially dangerous and must be kept out of children's reach and disposed of in a safe manner for the environment.



After unpacking check that the machine is not damaged. If in doubt, do not use the machine and contact a Carimali authorized Service Centre.

4.6 POSITIONING

The machine is not suitable for the installation in close proximity of water jets or heat sources. At a distance of 150 mm from walls or other objects to facilitate ventilation.

Position the appliance horizontally on a flat, stable surface so that the upper part of the machine is more than 1.5 metres above the floor.

4.7 INSTALLATION

The installation and commissioning of the machine must only be carried out by qualified technicians authorised by the manufacturer in accordance with all local safety regulations.

Before connecting the machine to the mains, ensure that the data on the rating plate corresponds to the mains supply data.

Before connecting it to the water mains, flush the water line and pipes to prevent dirt particles from entering the machine. Do not use used seals and pipes.

The mains water pressure must be between 0.1 Mpa (1 Bar) and 1.0 Mpa (10 Bar).

Connection to the water supply must comply with current regulations.

Only use the pipes and fittings supplied with the appliance; do not reuse old pipes and fittings.

4.8 MAINTENANCE

Unplug the machine from the mains and other power sources during all routine maintenance, testing or cleaning operations.

For machines equipped with a cable with a non-removable plug: if the power cable is damaged, it must be replaced by the manufacturer or its technical service or by qualified personnel in order to avoid any risk.

In case of power cord damage, have it replaced by the manufacturer, his authorised technical Service Centre or skilled personnel to prevent any risk.

For repairs, only contact a Service Centre authorised by the Manufacturer and require the use of original spare parts and accessories. Failure to comply with the above regulations could jeopardise machine safety.

For any communication regarding failures or malfunctioning, contact the nearest Service Centre, indicating the model, the type and the serial number of the machine. The data are shown on the relative rating plate.

If the machine is idle for any period of time, carry out the necessary maintenance operations before returning it to service to ensure it operates in excellent condition.

4.9 CLEANING

Before carrying out any intervention that involves manual cleaning of the internal parts, be sure to have cut off the power to the machine using the main switch or by disconnecting the power cable.

Do not clean the machine with direct jets of water and do not immerse it in water or other liquids. Always use the appropriate PPE, according to the current safety regulations in force.

Cleaning and maintenance must be carried out by the user and must not be carried out by unsupervised children.

The following parts should be cleaned at least once a day with soft, dry cloths or lightly moistened with water:

- Outer surface of the machine
- Display
- Drip tray

4.10 DISPOSAL

If the machine is no longer be used, it must be rendered inoperative. In particular, it is necessary to cut the power cord after the plug has been removed.

Once the machine is inoperative or decommissioned, the boiler(s) must be emptied.



When dismantled, this product shall not be discarded as household waste, and must be delivered to an authorised waste collection point for disposal of electric and electronic devices. For more detailed information on the recycling of this product, contact your local authorities or the local waste disposal service.

5. INSTALLATION



Make sure that the machine has been installed by qualified technical personnel, Installation must be carried out according to the manufacturer's instructions.



An incorrect installation can cause damage to persons, animals or things; the manufacturer declines all responsibility for such situation.

5.1 POSITIONING OF THE MACHINE

Place the machine on a table having minimum height of 0.7 mt to a maximum of 0,95mt. Furthermore the surface has to be flat, having a maximum inclination of 5°, in order to secure a perfect stability. Check also that the table can bear the weight of the machine.

At a minimum distance of 150 mm from walls or other objects, to facilitate ventilation.

Indoor with temperature above 5 °C.

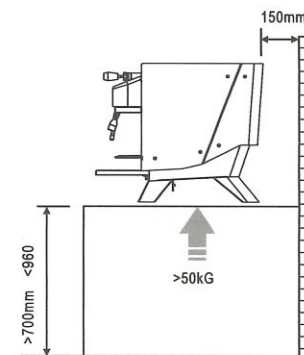

Do not cover the ventilation openings of the machine.

5.2 WATER MAINS CONNECTION



Never use the machine without water.



The mains water pressure must never exceed 10 bar (1.0 MPa); if this is not the case a qualified technician must fit a pressure reducer.

To prevent damages to the hydraulic system, the optimal range of the water hardness supplied to the machine by the water mains must be between 7 and 10 French Degrees (4 and 6 German Degrees).

- Before connecting to the water mains, flush the pipe with approximately 5 litres of water from the tap.
- For the correct use of the machine, it is essential for the customer to install an external Softener Filter with a water check valve system.
- Use only the supply tube supplied with the machine, connecting one end to the machine inlet solenoid valve and the other to the softener filter outlet. Take care not to crush the tube.
- Connect the softener filter to the water tap.
- Make sure the tap is open after connecting the machine to the water mains.

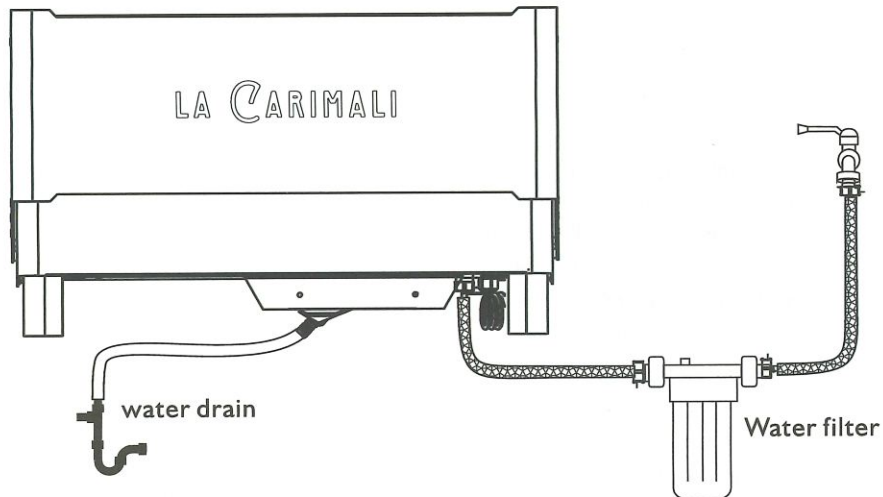

Only use water suitable for human consumption

5.3 POWER MAINS CONNECTION



The connection to the electricity mains must be made by a qualified technician in compliance with current regulations. The technician must make sure that the electrical system is properly connected to the earthing system and that the line voltage and frequency correspond to the data shown on the identification plate. Incorrect power supply voltages can cause serious damage to the system and to the machine. The Manufacturer shall not be held responsible for any damage caused if the above instructions are not followed or if the system is not connected to the earthing system.

1. Before connecting the machine to the power mains, make sure that the power-up switch is in the "0" position.
2. If the power cable is damaged, it must be replaced by a special cable or assembly, which is available from the manufacturer or its technical support service.
3. The machine has an output cable with a plug in accordance to the country regulation, connect it directly to the user's power supply.
4. Turn the power-up switch to the "1" position to power-up the machine; wait for the firmware to load and follow the on-screen procedure.

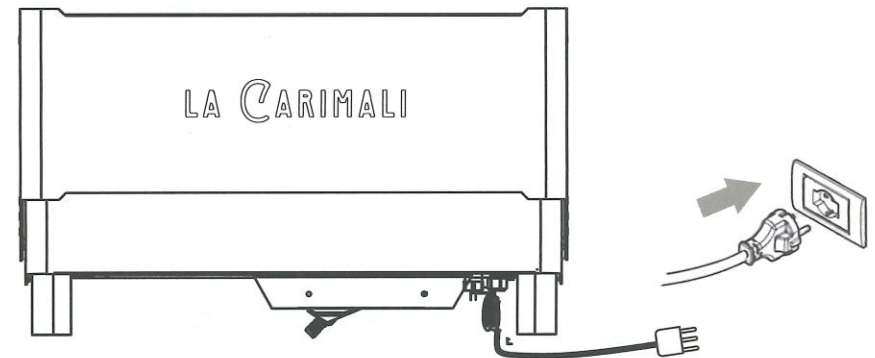

In case the plug do not match the used power supply socket do not force the connection, do not use any adapter and contact a professional installer.

5.4 POWER ON

1. After connecting the machine to the water supply, make sure that the tap is open.



2. Turn the power button to the "I" position to switch on the machine. The display shows the software version for a few seconds.

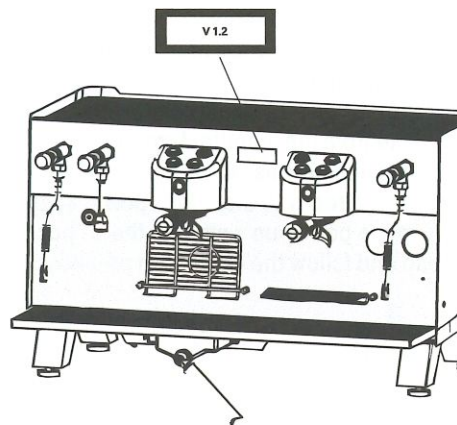

3. **Filling the boiler.**
At start-up, boiler filling begins automatically. This procedure stops when the level on the probe is reached.

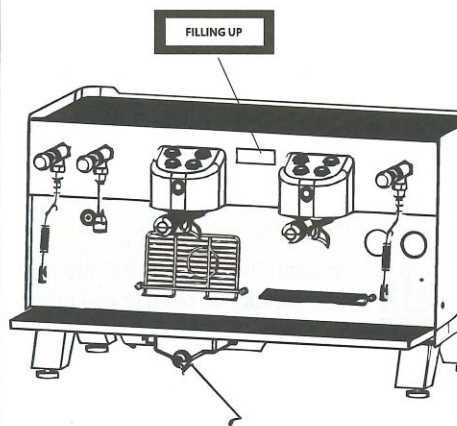

4. **Heating the boiler.**

During the heating stage, the display shows the boiler temperature and all LEDs on the button panel light up in sequence from right to left. Wait approx. 20 minutes for the set temperature to be reached.

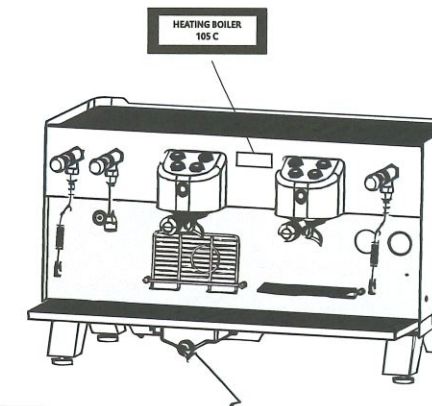

5. Once a temperature of 100° C is reached, keep the steam levers open for a few seconds to let residual water and steam escape from the circuit.

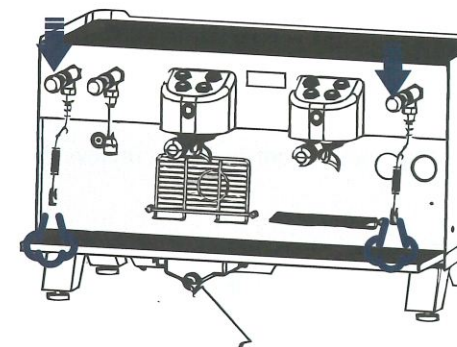

6. Once the pre-set temperature is reached, the display shows this message and the machine is ready for brewing. The buttons stay lit when the machine is on standby. When pressed to brew, only the corresponding key stays lit, the others are switched off.

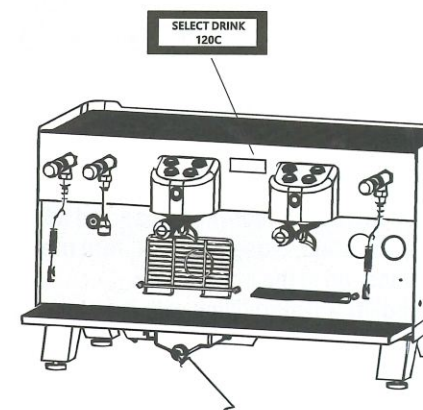

5.5 BOILER EMPTYING AT FIRST START-UP

After switching on the machine for the first time, it is necessary to empty the boiler to eliminate any residues.

This operation must be repeated once a week so that the water is periodically replaced;

Switch the machine off at the main switch.
Close the water main.
Allow the steam to escape by fully lowering the levers.

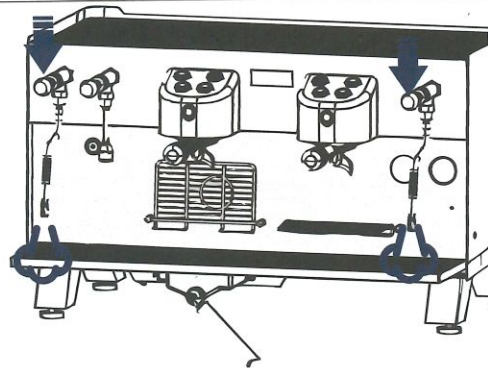

To empty water from the boiler, remove the front panel so that the drain tap is accessible.

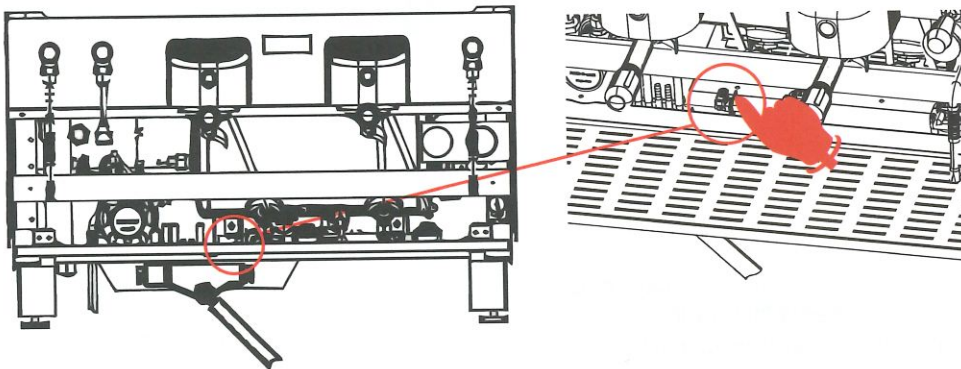

Open the tap counter-clockwise and allow the water in the boiler to flow fully into the drain. When finished, close the cock, refit the tray and grille, open the main water and switch the machine on in the normal way.

The boiler will start filling with the startup procedure described above.

5.6 CIRCUIT FLUSHING AT FIRST START-UP

When installed for the first time, dispense 1.5 litres of water from each delivery point by pressing the coffee group head dispensing buttons, those of the hot water wand, and lowering the levers so that steam comes out for 1 minute.

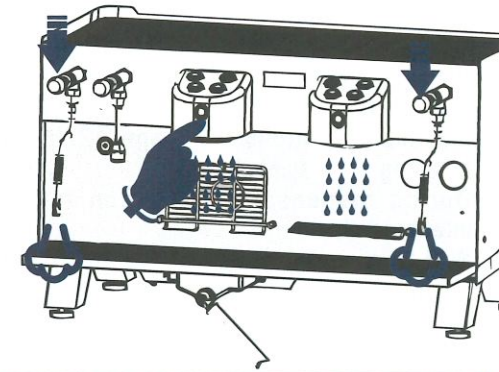

6. USE

6.1 COFFEE DISPENSING

Proceed with preparation of the first cups of coffee: Fill the filter with the correct quantity of ground coffee and press it lightly the special presser.



Insert the filter holder into the housing on the coffee group.

Dosage and grinding must be set according to the machine and strength of coffee desired.

If too much coffee is used, the filter holder cannot be inserted into the unit; if too little coffee is used, the coffee grounds become too wet.

For the perfect cup of coffee, it is advisable to have a self-dosing coffee grinder beside the machine.

This will result in improved quality of the coffee, and ensure that it is maintained since it is freshly ground.

Fit the filter holder into the group with the knob facing to the left, then turn it to the right until it locks.

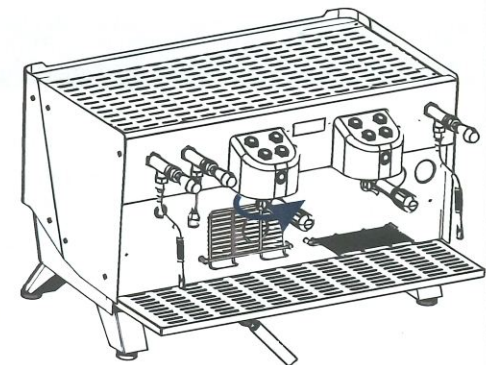

Place the cup under the spout.
 Press a button relating to the drink to be dispensed; refer to paragraph "3.2 Function of dispensing buttons" on page 12 for the meaning of the symbols.
 During dispensing the button flashes intermittently.
 Wait for dispensing to finish. To interrupt the operation in advance, press the button again.
 Each button dispenses according to a preset recipe; to change it, refer to paragraph 7.1 Changes to recipes" on page XX concerning recipe settings.

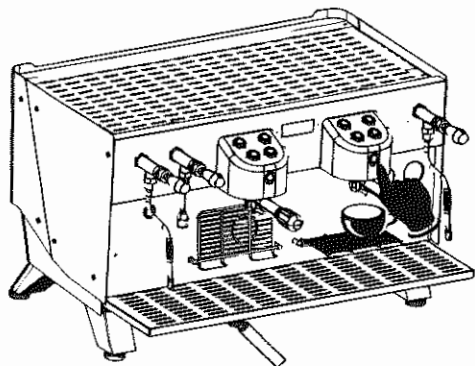

IMPORTANT

The physical state of the ground coffee is fundamental for a good beverage. When the coffee grounds have to be emptied out, knock the filters against a wooden surface and not a metal one as this could damage the edge of the filter and jeopardize its tightness.

Condition of the coffee

It comes out slowly

It comes out rapidly

Dose of ground coffee
 Pressure on ground coffee
 Atmospheric humidity
 Degree of grinder
 Filter condition

Excessive
 Excessive
 Too damp
 Too fine
 Partly clogged, dirty

Insufficient
 Insufficient
 Too dry
 Too coarse
 Holes enlarged by wear

6.2 STEAM DISPENSING

The steam dispensing is used to manually heat and froth the milk and is performed using the wand lever on the side of the machine, right or left, depending on the configuration.
 Place a container with milk under the wand and lower the lever.
 The more the lever is lowered, the greater the steam power delivered.
 At the end, lower the steam lever for a few seconds to flush out any liquids trapped inside the nozzle;
 this is an important operation because it prevents milk or other liquids from being sucked into the boiler.

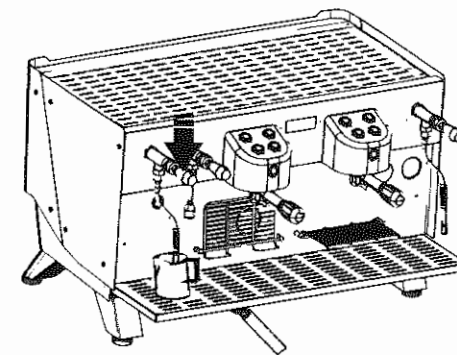

6.3 HOT WATER DISPENSING

A wand at the side of the machine dispenses only hot water for infused drinks.
 Place a container with milk under the wand and lower the lever.
 To interrupt the flow, move up the lever.

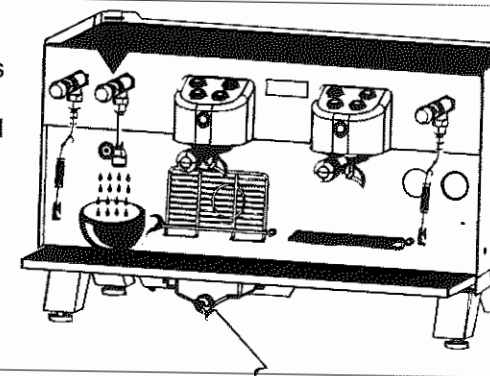

6.4 POWER OFF

To switch off the machine from the Home page, with the machine not performing any dispensing operation, press the main switch to the "0" position (backlight of the button will be off).
 Close the water supply.

7. PROGRAMMING

7.1 PROGRAMMING DOSES

With the machine switched on in brewing mode, press the  button on the panel of the first group on the left and hold it down for **ten seconds** until you see GR.X PROGRAMMING.

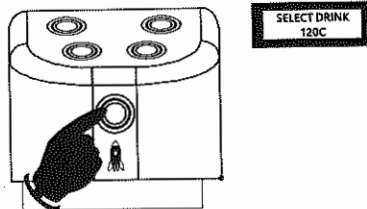

Programming level is accessed, indicated by the flashing LEDs for all buttons and a message that appears on the display (Gr.x PROGRAMMING)

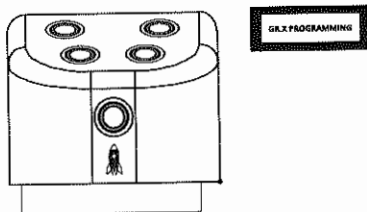

Put the coffee you intended to use in filter and install it on the group, put a graduated cup under the coffee spout. Press the buttons for the dose of coffee to be programmed. A message shown in the figure is displayed for each one.

Brewing begins and the display shows the number of seconds of the duration.

When the quantity of desired coffee will be delivered press the key on the selected beverage once more to stop brewing and automatically store the **dose quantity**.

The programming carried out on the left-hand group is carried over to all the machine's button panels.

If different doses are required on the various buttons, repeat the procedure on the right-hand button panel.

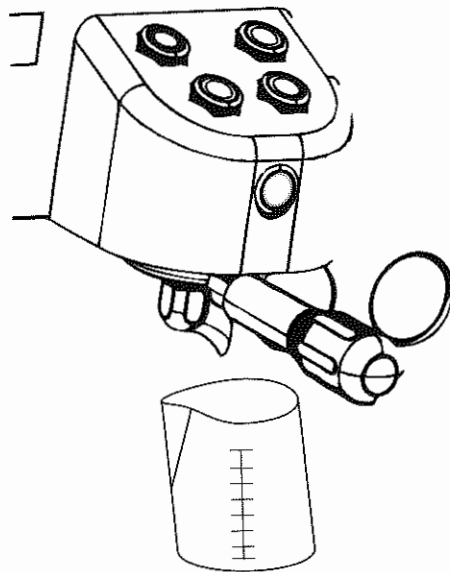

When programming is complete, after a few seconds the machine returns to its initial brewing mode.

SELECT DRINK
120C







IMPORTANT

To exit the programming stage without making any changes, wait thirty seconds without pressing any keys.

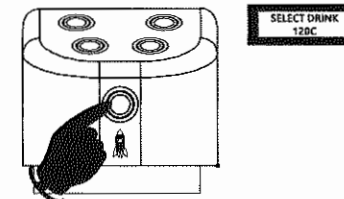
7.2 READING AND RESETTING COUNTERS

With the machine switched on in brewing mode, press the  button on the panel of the first group on the left and hold it down for **five seconds** until you see DOSE COUNTERS



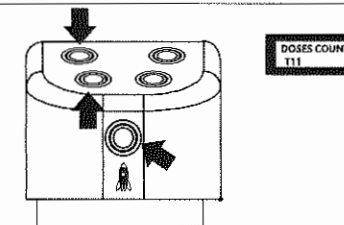

The following programme items will be accessible, each of which can be modified by pressing keys  and  and pressing  key to confirm.



Doses counter

Checking the counter to monitor the doses dispensed by each key/beverage. The abbreviation T1 indicates Coffee Group 1 to which the number of the key is added e.g. T11.

If you wish to scroll between buttons, press  and , the data of other brews will be seen (T12, T13, T14, etc.), and the number of doses associated with them.

Press  to move on to the subsequent parameter.

DOSES COUNTER
T11 15

Cleaning cycle

Checking the counter to monitor the cleaning carried out by each group present (GR). Press buttons and to scroll through the groups and review the number of cleanings performed for each key. Press to move on to the subsequent parameter.

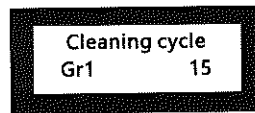

Reset dose count

Counter reset to reset the doses logged by the software. Press buttons and to enable YES or NO and then key to confirm.

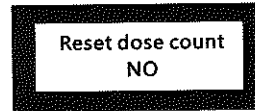

Reset cleaning

Counter reset to reset the cleanings logged by the software. Press buttons and to enable YES or NO and then key to confirm.

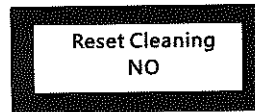

7.3 EDITING PARAMETERS

Turn off the machine

Turn the machine on by holding down the (continue/program) button until the display enters edit mode.

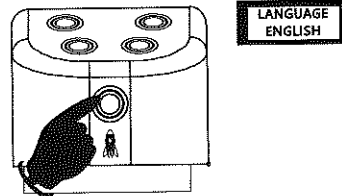

The following programme items will be accessible, each of which can be modified by pressing keys and and pressing key to confirm, press to exit the programming.

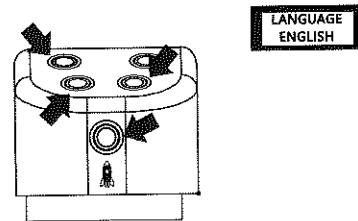

Languages

To set the desired language from those present in the software on the display (Italian, English, German, Dutch, Polky, Espaniol)



Temperature measurement unit

To change the temperature display mode, °C or °F.

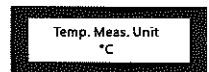

Boiler temperature

To change the boiler temperature, from a minimum of 116°C to a maximum of 126°C.



Pre-infusion

Different pre-infusion can be set for each button except the continuous pouring.

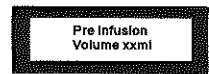

Once the Pre-infusion Volume xxml will be display all the buttons will be ON, select the one you want to set. The selceted buttons with remain ON and the other will be off.



After confirming the Volume on the next item the pause can be set in the similar way. After confirming the pause the software will be back to pre-infusion volume and another button can be set.

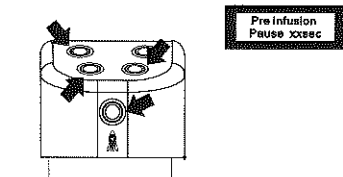

Water filter

To program the number of liters for the water filter. This parameter can be used when the machine is connected to a water softener to prevent scale formation in the hydraulic system. When the set parameter is reached, the machine displays a WATER FILTER alarm.

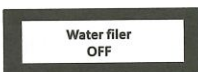

Interface I/o Hw

Used to activate the serial port on the machine mainboard and set the baudrate .

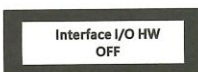

Stopwatch enabled

Enabling of counting (in seconds) of the dispensing time on the display.

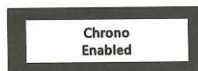

8. CLEANING



IMPORTANT

Read and strictly respect the safety instructions before performing any type of intervention on the machine. See the Quick Guide supplied with the machine.



WARNING

Do not use solvents, chlorine-based products or abrasive agents to carry cleaning operations. Do not clean the machine with direct water jets and never immerse the machine in water or other liquids.

Pay attention to the steam generated during the various procedure as it can reach very high temperature: to prevent scalding, adjust the temperature of the water used.

8.1 NON-ORDINARY MAINTENANCE AND SERVICE OPERATION



QUALIFIED TECHNICIAN

Non-routine maintenance and service operations must only be carried out by professionally qualified personnel. Extraordinary interventions are only permitted to trained and experienced personnel.

8.2 CLEANING FREQUENCY TABLE

Operation	Type	Frequency
Display	Manual	Daily
Machine surface	Manual	Daily
Water/steam wand	Manual	Daily
Coffee group	Semi-automatic	Daily
Boiler empty	Manual	Weekly
Shower filter, portafilter	Manual	Weekly
Tray	Manual	Daily

8.3 DISPLAY CLEANING

Clean the display with a soft, dry cloth.

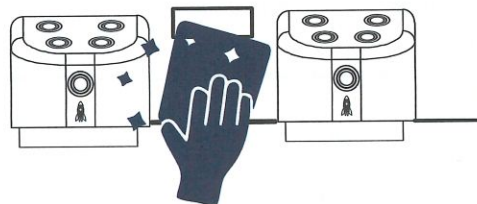

8.4 CLEANING OF MACHINE SURFACE

Clean the exterior of the machine daily using a non-abrasive sponge moistened with a non-aggressive detergent. Rinse thoroughly and dry with a soft cloth.

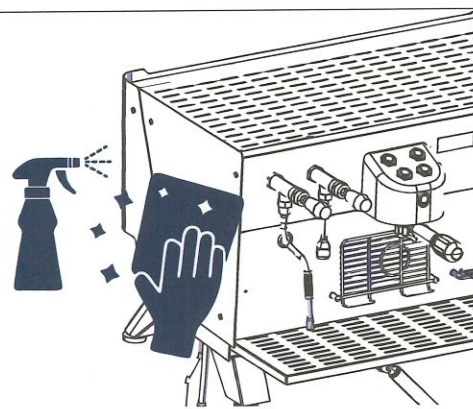

8.5 WAND CLEANING

Clean the wands frequently with a damp cloth to prevent residues from encrusting the surface. Perform a few dispensing operations with steam only to remove milk residues from inside the wands. Clean also the outside of the hot water wand.

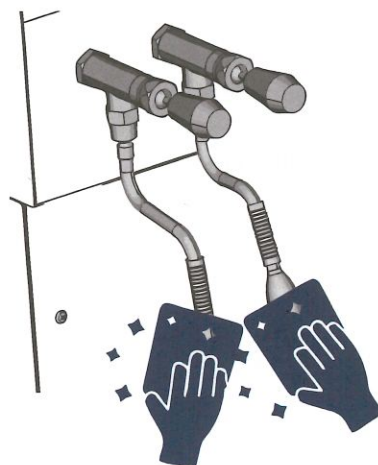

Steam wand

- 1 Take a container with 500ml of cold water and mix with 50 ml of Carimali liquid detergent.
- 2 Put the steam wand in the container and, for a total of 10 times, lower and lift the steam wand (1 second low, 10 seconds high).
- 3 Take out the steam wand and discard the liquid.
- 4 Fill the container again with cold water only and repeat the operation described in step 2.
- 5 Take out the steam wand and discard the liquid.
- 6 Complete the procedure by repeating the operations in step 2.

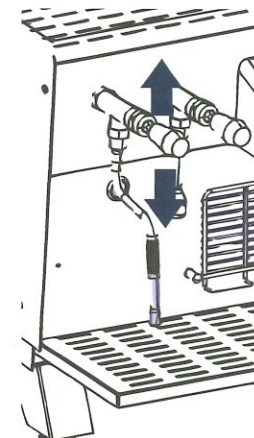

Clean with sanitising liquid every day after the work shift.

IMPORTANT

8.6 COFFEE GROUP CLEANING



Carry out cleaning every day at the end of the work shift.

IMPORTANT

- Insert the rubber cap on the filter
- Put a tablet of detergent in the filter.
- Insert the filter holder into its housing.

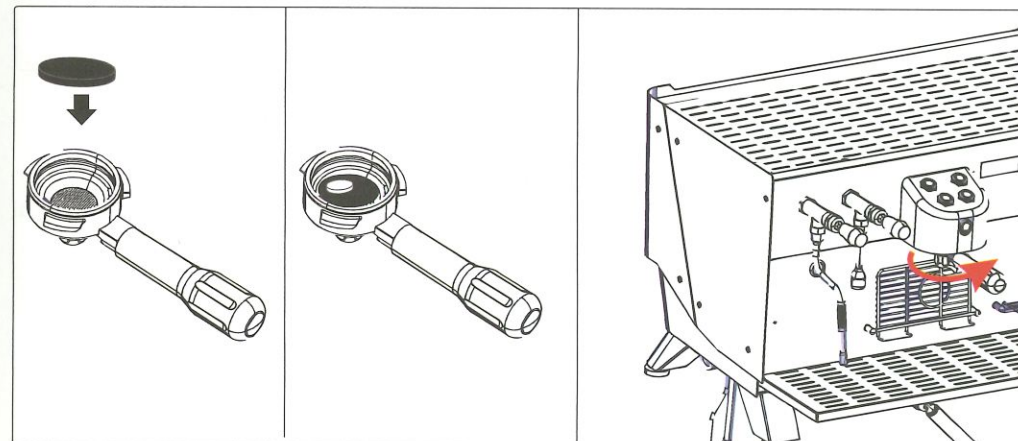

Switch off the machine.

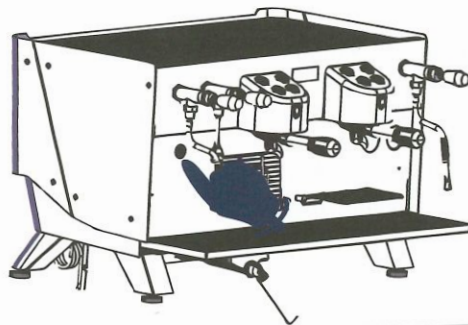

Switch the machine on using the main switch while simultaneously holding down keys ☐ and ☐ (of the group to be washed) until the button LEDs light up and the message Cleaning, where "GR1" stands, for example, for Group 1.

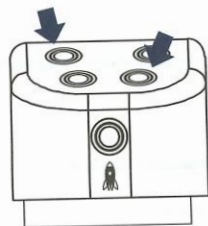

GR1 CLEANING 10

Hold down until dispensing begins, which consists of ten pulses for a total duration of 100 seconds.

Wait until dispensing is complete, then remove the filter holder and remove the blind filter. Make a number of no-load brews before resuming normal operation.

Repeat the same operation for the other groups.

8.7 PERIODIC BOILER EMPTYING

Empty the boiler at least once a week to replace the water. For this procedure, refer to the Chapter 5. INSTALLATION in paragraph "5. 5 Boiler emptying at first start-up".

8.8 CLEANING OF THE SPRAYHEAD, FILTER HOLDER AND FILTER



Carry out this operation when the machine is cold and with the main switch in the "0" position.

To remove other coffee residues, use the brush supplied to wipe the coffee group spray head and the filter holder.

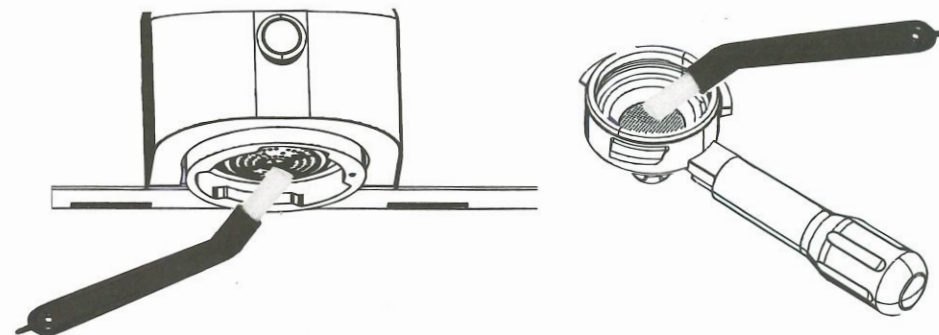

Dismantle the shower screen once a week and clean it thoroughly. Remove the shower screen by unscrewing the screw (A) at the center. The block will fall downwards.



Also remove the gasket (B) and detach the o-ring (C) from the block.

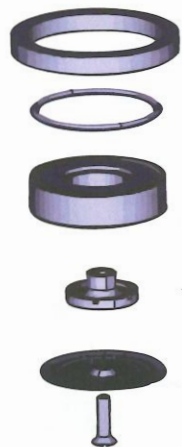

Prepare a container with about 500ml of very hot water and insert a cleaning tablet (the kind recommended by Elektra). Soak all metal components for about 10 minutes. When finished, remove them from the container and rinse them under hot running water, scrubbing them with the brush supplied. Reassemble the shower screen by performing the operations in reverse order.

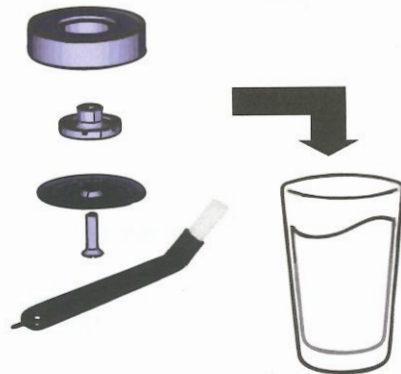

To replace the gaskets or other consumable components, refer to the Manufacturer's maintenance plan or to the state of wear of the parts themselves.

IMPORTANT

-Lift the grill.
-Lift the bowl and remove it, empty it out and wash it well using water and dishwashing detergent. If necessary, remove any residues with a pipe cleaner;

Check that the direct drain is not clogged as this could cause the tank to fill up and stop the machine from working.

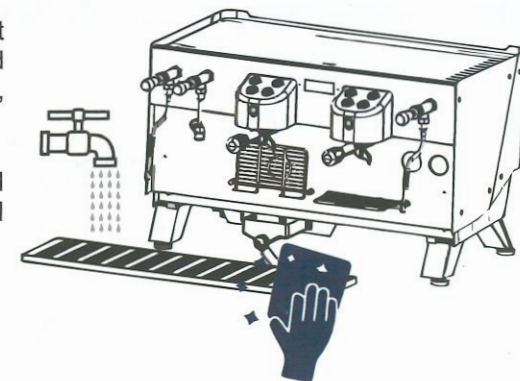

Rinse with warm running water and dry carefully to avoid bacterial proliferation.

IMPORTANT

9. ERROR MESSAGES

ALARM CODE	ERROR TYPE	DESCRIPTION	CHECK
FILLING UP T.O.	Boiler filling alarm	Filling Time Out. The boiler filling stage has exceeded the maximum time of 120 sec.	Check that the water feed cock is open.
			Check that the water connection pipe is not crushed or disconnected.
			If the problem persists, contact Technical Support.
HEATING T.O.	Set temperature reaching alarm	The programmed temperature has not been reached within the maximum limit of 30 minutes.	Try switching the machine off and on again.
			If the problem persists, contact Technical Support.
FLOW METER GR.X	Water delivery failure alarm	The machine is operational but no coffee comes out.	Check that the water feed cock is open.
			Check that the water connection pipe is not crushed or disconnected.
			Check that the quantity of coffee in the filter is not excessive.
			Check that the grinding is not too fine. Check that the grinding is not too fine.
			If the problem persists, contact Technical Support.
INFUSION T.O.	Water delivery time out alarm	Time limit of 120 seconds reached where insufficient dispensing has taken place	Check that the quantity of coffee in the filter is not excessive.
			Check that the grinding is not too fine.
			If the problem persists, contact Technical Support
TEMPER. PROBE	The LEDs of keys 1, 2 and 4, 5 flash alternately for each group	Probe temperature fault	Try switching the machine off and on again
			If the problem persists, contact Technical Support
WATER FILTER	Warning of the number of litres reached for which the water filter is designed.	This alarm is programmable by the filter manufacturer	Contact Technical Support

10. LED LIGHTS

Glow is provided of a decorative RGB LED line on the back. This can be set through the holes on the top of the machine.

The RGB LED strip has 20 built-in colors and two working modes.
 Mode 1: Fix color. The RGB LED strip emits light of the selected color. The color can be chose from built-in colors by pushing the two buttons on the surface of LED controller. One for next, and another for last. After 5 seconds, the choice will be saved, no loss when power is lost.

Mode 2: Smooth color changing. The light color of LED strip changes smoothly in cycles between 20 built-in colors. Press and hold any button for at least 3 seconds.

To access the led control box remove the rubber protection. With a tool press the small buttons on the LED control box.