

ALFA420H-2

HUMIDIFIED CONVECTION OVEN - THREE PHASE (SINGLE PHASE OPTIONAL)

4 Tray capacity, 600x400mm (wire racks supplied) / GN1/1 (optional)



GUARANTEED COOKING PERFORMANCE

Smeg catering products draw on the experience of approximately 40 years in the Foodservice industry. The ovens are built with the highest quality materials, making them particularly tough and strong.

FAN SYSTEM

The heat in the oven is distributed by the means of two fans, which are turning in opposite directions, with timed direction reversal. This alternating operation guarantees uniform cooking and enhances the browning of food products in all larger cavities.

VERSATILITY

The complete Smeg Foodservice catalogue offers a range of ovens for all needs and environments, fulfilling any requirement in the most efficient and high-performing way.

PRODUCT FEATURES

- Compact and functional design, robust stainless steel construction
- Full stainless steel oven cavity
- Manual electromechanical controls, extremely simple and reliable
- **Rack suitable both for 600x400 and GN1/1* trays**
- **Excellent baking uniformity across all trays, due to two fans rotating in opposite directions and with timed rotation reversal. This ensures a perfect heat distribution in all conditions of use**
- Excellent internal visibility due to the large glass and powerful inner light
- Double glass door, with internal glass removable for cleaning
- **Manual humidifier, through a plumbed water system connection**
- **Electrical connection: Three phase - 6.9kW (Standard) / Single phase, 6.9kW (optional). Turn to page 2 for more information.**
- 4 wire racks (model 3805) included
- Dimensions (mm) (WxDxH): 800x747x563
- **24 months parts and labour warranty**

ACCESSORIES

- TVL425 & TVL425D - Stainless steel stand
- 3743 - Flat aluminium tray
- 3805 - Wire racks
- 3810 - Undulated wire racks
- 3751 - Flat aluminium tray with holes

* GN1/1 with minimum 20mm depth

ALFA420H-2

HUMIDIFIED CONVECTION OVEN - THREE PHASE (SINGLE PHASE OPTIONAL)

4 Tray capacity, 600x400mm (wire racks supplied) / GN1/1 (optional)

TECHNICAL SPECIFICATIONS

Dimensions (mm) (WxDxH)	800x747x563
Trays (mm)	600x400
Tray capacity	4
Distance between trays (mm)	77
Control type	Manual
Door/hood structure	Stainless steel
Temperature range (°C)	50 - 270°C
Timer	1 - 60min + manual
Power rating & electrical connection	Standard: 400V 3N~/17A/6.9kW/50 Hz Optional: 230V~/30A/6.9kW/50 Hz
Net weight	61kg

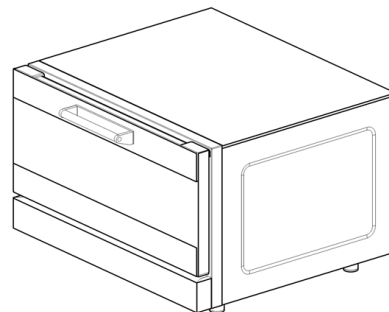
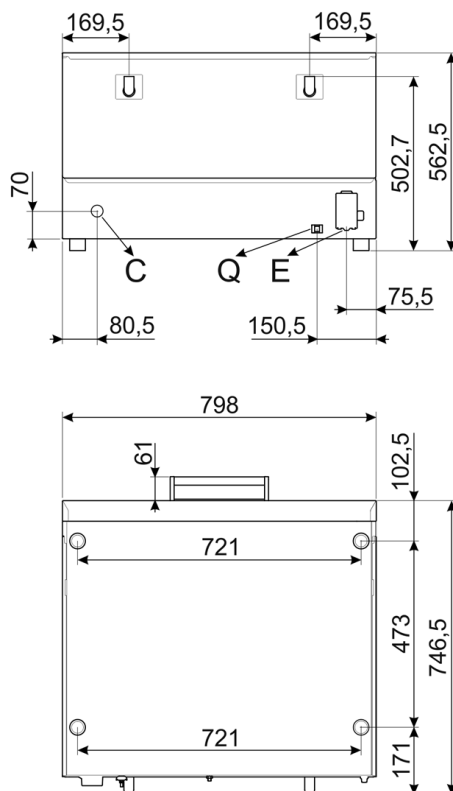

Q	MORSETTO EQUIPOTENZIALE EARTH TERMINAL
E	CAVO ALIMENTAZIONE ELETTRICA ELECTRICITY SUPPLY CABLE
C	TUBO DI CARICO (solo su alcuni modelli) FILLER HOSE (on some models only)

