

ALFA1035H-2

HUMIDIFIED CONVECTION OVEN - THREE PHASE

10 Tray capacity, 600x400mm (wire racks supplied) / GN1/1 (optional)

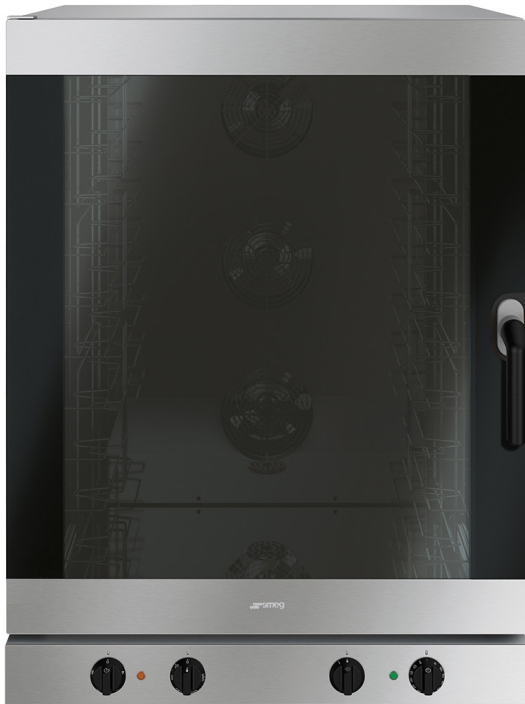

GUARANTEED COOKING PERFORMANCE

Smeg catering products draw on the experience of approximately 40 years in the Foodservice industry. The ovens are built with the highest quality materials, making them particularly tough and strong.

FAN SYSTEM

The heat in the oven is distributed by the means of three fans, which are turning in opposite directions, with timed direction reversal. This alternating operation guarantees uniform cooking and enhances the browning of food products in all larger cavities.

VERSATILITY

The complete Smeg Foodservice catalogue offers a range of ovens for all needs and environments, fulfilling any requirement in the most efficient and high-performing way.

PRODUCT FEATURES

- Robust stainless steel construction, modern and functional design
- Full stainless steel oven cavity
- **Manual electromechanical controls, extremely precise, simple and reliable**
- **Adjustable rack suitable both for 600x400 and GN1/1* trays**
- **Excellent baking uniformity across all trays, due to two fans rotating in opposite directions and with timed rotation reversal. This ensures a perfect heat distribution in all conditions of use**
- Excellent internal visibility due to the large glass and powerful inner light
- **Cool door with double glass**
- Double-stage door opening system
- **Manual humidifier through a plumbed water system connection**
- **Electrical connection: Three phase**
- 4 wire racks (model 3805) included
- Dimensions (mm) (WxDxH): 798x772x1100
- **24 months parts and labour warranty**



ACCESSORIES

- TVL425D - Stainless steel stand
- 3743 - Flat aluminium tray
- 3805 - Wire racks
- 3810 - Undulated wire racks
- 3751 - Flat aluminium tray with holes

* GN1/1 with minimum 20mm depth

ALFA1035H-2

HUMIDIFIED CONVECTION OVEN - THREE PHASE

10 Tray capacity, 600x400mm (wire racks supplied) / GN1/1 (optional)

TECHNICAL SPECIFICATIONS

Dimensions (mm) (WxDxH)	798x772x1100
Trays (mm)	600x400
Tray capacity	10
Distance between trays (mm)	77
Control type	Manual
Door/hood structure	Stainless steel
Temperature range (°C)	50 - 270°C
Timer	1 - 60min + manual
Power rating & electrical connection	400V 3N~/40A/16kW/50Hz
Net weight	102kg

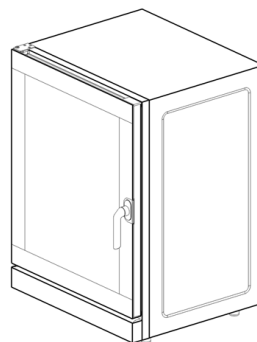
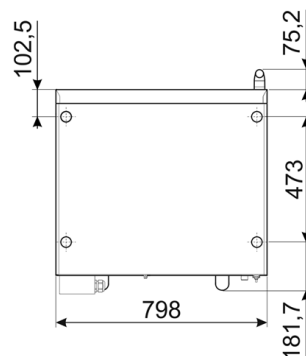
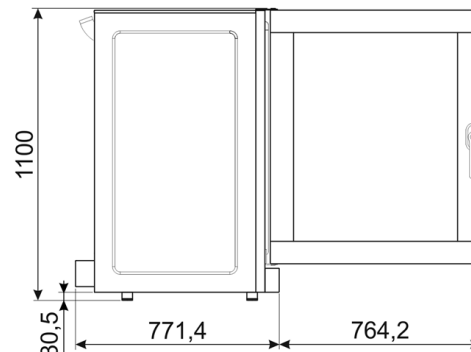
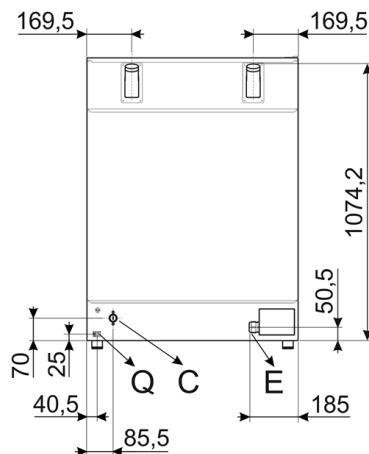

Q	MORSETTO EQUIPOTENZIALE EARTH TERMINAL
E	CAVO ALIMENTAZIONE ELETTRICA ELECTRICITY SUPPLY CABLE
C	TUBO DI CARICO FILLER HOSE



UNI EN ISO 9001
9130-Smeg

UNI EN ISO 14001
9191-SME2

OHSAS 18001
9192-SME3