



AAF.45W.RM

THREE TUBE BURNER FRYER



PROJECT	_____
ITEM	_____
QUANTITY	_____
DATE	_____

The Three Tube Burner Fryer Series is designed for heavy duty use and performance. All the latest technology is incorporated to provide the best value for money.

Quality, dependability and customer satisfaction make American Range the ultimate choice.

FEATURES & BENEFITS:

- Stainless Steel exterior on front, sides and top
- Stainless Steel durable double skinned access door
- Removable basket hanger accommodates two fryer baskets
- Millivolt control system, no electrical hook up required
- Fryer - Manually lit with pilot
- Chrome plated basket support under the fry baskets
- High efficiency cast iron tube burners for fast recovery time
- Deflector/baffle design absorbs and diffuses heat efficiently to tube walls
- Combination gas valve includes built in pressure regulator
- Front sloping vessel bottom traps food particles, prevents carbonization in the fry zone, reduces flavor transfer, and extends oil life

TECHNICAL DATA:

Dimensions (W x D x H):	394 x 828 x 1118
Total Weight:	75 Kg
Cooking Area (W x D x H):	356 x 356 x 220mm
Oil Capacity:	22 Litres

GAS DETAILS	Natural Gas (NG)	Universal LP Gas (ULPG)
Minimum Supply Pressure	1.13 kPa	2.75 kPa
Operating Pressure	1.0 kPa	2.49 kPa
Total Gas Supply	90MJ/Hr	72MJ/Hr

3/4" BSP connection

NOTE: It is the responsibility of the installing gas plumber to ensure correct supply and connection sustaining appropriate pressure when all appliances are full on.

OPTIONAL EXTRAS:

- Fryer lids
- Fish plates
- Splash guards
- Capping strips

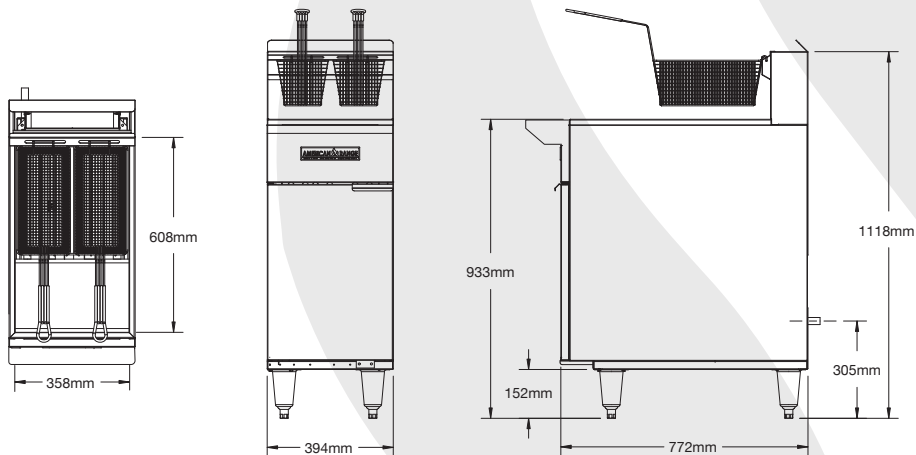

Due to continuous product research and development, the information contained herein is subject to change without notice.
Revision: 15/8/2019