



VORTEX

hand-held mixers



- Efficient engine cooling system
- Sturdy, lightweight ABS frame Glass Filled
- Practical and ergonomic handle
- Rubber bumpers to cushion contact with the containers
- Powerful performance engines
- Available in two versions of commands:
 - Fixed speed
 - VT: (Variotronic) speed control with stabilizer
- Push button safety system against accidental ignition
- Available in 3 different engines
- The machine is protected with IPX3
- Quick coupling system
- totally removable rods for a thorough cleaning which extends their life
- Hub and completely in stainless steel bell
- Whisk with metal gearing, demountable and in the dishwasher

Options:

- Storage case
- Bowl support
- Wall support
- Display stand



WHISK



SHAFT 35



SHAFT 45



VORTEX 43



VORTEX/CICLONE
Optional display stand



Self-supporting structure with 3 display stands



Air intake IP x3



Quick tool assembly



Whisk release



Bell and knives of stainless steel



Optional wall support

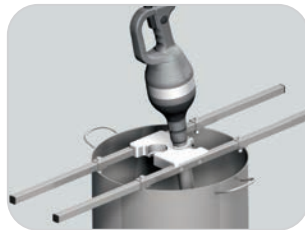

Optional bowl support

VARITRONIC™
SYSTEM

VT: Speed control with stabilizer



Removable shafts

Removable knives

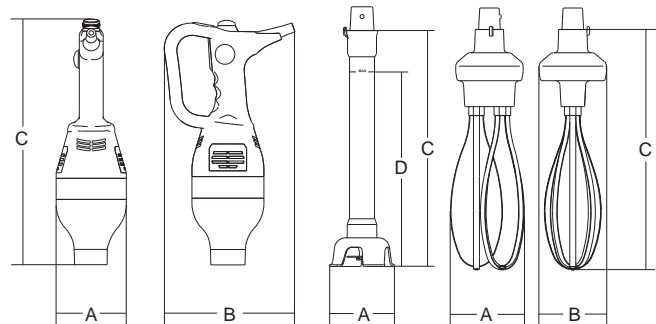

						A	B	C	D			
	watt/HP		r.p.m.	r.p.m.	lt	mm	mm	mm	mm	kg	mm	kg
Vortex 43	430/0.60	1ph	1.850	13.000	100	125	190	377	-	2.5	570x300x180	3
Vortex 43 VT	430/0.60	1ph	350÷1.800	2.200÷11.500	100	125	190	377	-	2.5	570x300x180	3
Vortex 55	550/0.80	1ph	1.900	13.500	200	125	190	385	-	3.5	570x300x180	3.7
Vortex 55 VT	550/0.80	1ph	350÷1.800	2.200÷11.500	200	125	190	385	-	3.5	570x300x180	3.7
Vortex 75	750/1	1ph	1.950	14.000	300	125	190	390	-	4	570x300x180	4.5
Vortex 75 VT	750/1	1ph	350÷1.800	2.200÷11.500	300	125	190	390	-	4	570x300x180	4.5
Asta 35	-	-	-	-	-	∅ 100	-	415	350	1	490x230x150	1.5
Asta 45	-	-	-	-	-	∅ 100	-	515	450	1.5	590x230x150	2
Frusta	-	-	-	-	-	117	113	385	-	2	520x210x250	2.5