

SIGIX M20

sigilla vaschette
thermosealers



- Practical and robust manual thermosealers
- Stainless steel AISI 304 structure
- Electronic control with temperature and preheat counting trays
- welding time 4 sec.
- Molds to custom design
- aluminum plate sealer Teflon

Options:

- available trays
- mm 137x95 h.63
- mm 190x137 h.72
- mm 230x190 h.65
- mm 260x190 h.65
- Molds of the available trays

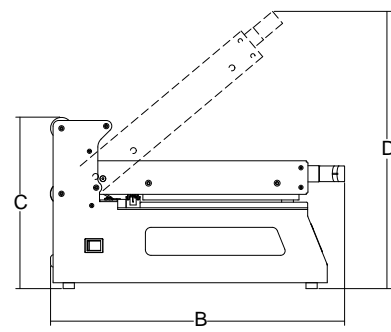
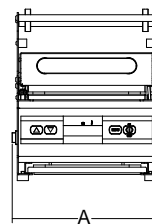

	watt	1ph	mm	mm	mm	mm	mm	mm	kg	mm	kg
Sigix M20	900	1ph	200	260x190	257	525	306	496	18	620x380x400	22