

## Magistar Combi DI Electric Combi Oven 10GN2/1

ITEM # \_\_\_\_\_

MODEL # \_\_\_\_\_

NAME # \_\_\_\_\_

SIS # \_\_\_\_\_

AIA # \_\_\_\_\_



218933 (ZCOE102C2S0)

\* NOT TRANSLATED \*

### Short Form Specification

#### Item No.

- Combi oven with digital interface with guided selection.
- Boilerless steaming function to add and retain moisture.
  - AirFlow air distribution system to achieve maximum performance with 5 fan speed levels.
  - HP Automatic Cleaning: Automatic and built-in self cleaning system. 5 automatic cycles (soft, medium, strong, extra strong, rinse-only).
  - Cooking modes: Programs (a maximum of 100 recipes can be stored); Manual (steam, combi and convection cycles); EcoDelta cooking cycle.
  - Automatic backup mode to avoid downtime.
  - USB port to download HACCP data, programs and settings. Connectivity ready.
  - Single sensor core temperature probe.
  - Double-glass door with LED lights.
  - Stainless steel construction throughout.
  - Supplied with n.1 tray rack 2/1 GN, 67 mm pitch.

### Main Features

- Digital interface with LED backlight buttons with guided selection.
- Boilerless steaming function to add and retain moisture for high quality, consistent cooking results.
- Dry hot convection cycle (max 300 °C) ideal for low humidity cooking. Automatic moistener (11 settings) for boiler-less steam generation.
- EcoDelta cooking: cooking with food probe maintaining preset temperature difference between the core of the food and the cooking chamber.
- Programs mode: a maximum of 100 recipes can be stored in the oven's memory, to recreate the exact same recipe at any time. 4-step cooking programs also available.
- AirFlow air distribution system to achieve maximum performance in chilling/heating evenness and temperature control thanks to a special design of the chamber combined with high precision variable speed fan.
- Fan with 5 speed levels from 300 to 1500 RPM and reverse rotation for optimal evenness. Fan stops in less than 5 seconds when door is opened.
- Single sensor core temperature probe included.
- Automatic fast cool down and pre-heat function.
- HP Automatic Cleaning: Automatic and built-in self cleaning system. 5 automatic cycles (soft, medium, strong, extra strong, rinse-only).
- Grease Collector: predisposed for integrated grease drain and collection for safer operation (dedicated base as optional accessory).
- USB port to download HACCP data, share cooking programs and configurations. USB port also allows to plug-in sous-vide probe (optional accessory).
- Connectivity ready for real time access to connected appliances from remote and HACCP monitoring (requires optional accessory).
- Back-up mode with self-diagnosis is automatically activated if a failure occurs to avoid downtime.
- 2 different chemical options available: solid and liquid (requires optional accessory).
- [NOT TRANSLATED]
- Connectivity ready for real time access to connected appliances from remote and data monitoring (requires optional accessory – contact the Company for more details).

### Construction

- Double thermo-glazed door with open frame construction, for cool outside door panel. Swing hinged easy-release inner glass on door for easy cleaning.
- Seamless hygienic internal chamber with all rounded corners for easy cleaning.
- 304 AISI stainless steel construction throughout.
- Front access to control board for easy service.
- IPX 5 spray water protection certification for easy cleaning.
- Supplied with n.1 tray rack 2/1 GN, 67 mm pitch.

### Optional Accessories

- Water softener with cartridge and flow meter (high steam usage)  PNC 920003

APPROVAL: \_\_\_\_\_

- Water softener with salt for ovens with automatic regeneration of resin PNC 921305
- Resin sanitizer for water softener (921305) PNC 921306
- Wheel kit for 6 & 10 GN 1/1 and 2/1 GN oven base (not for the disassembled one) PNC 922003
- Pair of AISI 304 stainless steel grids, GN 1/1 PNC 922017
- Pair of grids for whole chicken (8 per grid - 1,2kg each), GN 1/1 PNC 922036
- AISI 304 stainless steel grid, GN 1/1 PNC 922062
- AISI 304 stainless steel grid, GN 2/1 PNC 922076
- External side spray unit (needs to be mounted outside and includes support to be mounted on the oven) PNC 922171
- Pair of AISI 304 stainless steel grids, GN 2/1 PNC 922175
- Baking tray for 5 baguettes in perforated aluminum with silicon coating, 400x600x38mm PNC 922189
- Baking tray with 4 edges in perforated aluminum, 400x600x20mm PNC 922190
- Baking tray with 4 edges in aluminum, 400x600x20mm PNC 922191
- Pair of frying baskets PNC 922239
- AISI 304 stainless steel bakery/pastry grid 400x600mm PNC 922264
- Double-step door opening kit PNC 922265
- Grid for whole chicken (8 per grid - 1,2kg each), GN 1/1 PNC 922266
- Kit universal skewer rack and 6 short skewers for Lengthwise GN 2/1 and Crosswise ovens PNC 922325
- Universal skewer rack PNC 922326
- 6 short skewers PNC 922328
- Water nanofilter for 10 GN 2/1 & 20 GN 1/1 & 2/1 ovens PNC 922344
- External reverse osmosis filter for ovens 10 GN 2/1 & 20 GN 1/1 & 2/1 ovens PNC 922345
- Multipurpose hook PNC 922348
- 4 flanged feet for 6 & 10 GN , 2", 100-130mm PNC 922351
- Grease collection tray, GN 2/1, H=60 mm PNC 922357
- Grid for whole duck (8 per grid - 1,8kg each), GN 1/1 PNC 922362
- Thermal cover for 10 GN 2/1 oven and blast chiller freezer PNC 922366
- Tray support for 6 & 10 GN 2/1 disassembled open base PNC 922384
- Wall mounted detergent tank holder PNC 922386
- - NOT TRANSLATED - PNC 922390
- Tray rack with wheels 10 GN 2/1, 65mm pitch (std) PNC 922603
- Tray rack with wheels, 8 GN 2/1, 80mm pitch PNC 922604
- Slide-in rack with handle for 6 & 10 GN 2/1 oven PNC 922605
- Bakery/pastry tray rack with wheels 400x600mm for 10 GN 2/1 oven and blast chiller freezer, 80mm pitch (8 runners) PNC 922609
- Open base with tray support for 6 & 10 GN 2/1 oven PNC 922613
- External connection kit for detergent and rinse aid PNC 922618
- Stacking kit for electric 6 GN 2/1 oven placed on electric 10 GN 2/1 oven PNC 922621
- Trolley for slide-in rack for 6 & 10 GN 2/1 oven and blast chiller freezer PNC 922627
- Trolley for mobile rack for 6 GN 2/1 on 6 or 10 GN 2/1 ovens PNC 922631
- Stainless steel drain kit for 6 & 10 GN oven, dia=50mm PNC 922636
- Plastic drain kit for 6 & 10 GN oven, dia=50mm PNC 922637
- Trolley with 2 tanks for grease collection PNC 922638
- Grease collection kit for open base (2 tanks, open/close device and drain) PNC 922639
- Banquet rack with wheels holding 51 plates for 10 GN 2/1 oven and blast chiller freezer, 75mm pitch PNC 922650
- Dehydration tray, GN 1/1, H=20mm PNC 922651
- Flat dehydration tray, GN 1/1 PNC 922652
- Open base for 6 & 10 GN 2/1 oven, disassembled PNC 922654
- Heat shield for 10 GN 2/1 oven PNC 922664
- Heat shield-stacked for ovens 6 GN 2/1 on 10 GN 2/1 PNC 922667
- Kit to fix oven to the wall PNC 922687
- 4 high adjustable feet for 6 & 10 GN ovens, 100-115MM PNC 922688
- Tray support for 6 & 10 GN 2/1 open base PNC 922692
- Wifi board (NIU) PNC 922695
- - NOT TRANSLATED - PNC 922696
- Detergent tank holder for open base PNC 922699
- Mesh grilling grid PNC 922713
- Probe holder for liquids PNC 922714
- Odourless hood with fan for 6 & 10 GN 2/1 electric ovens PNC 922719
- Condensation hood with fan for 6 & 10 GN 2/1 electric oven PNC 922724
- 4 high adjustable feet for 6 & 10 GN ovens, 230-290mm PNC 922745
- Tray for traditional static cooking, H=100mm PNC 922746
- Double-face griddle, one side ribbed and one side smooth, 400x600mm PNC 922747
- TROLLEY FOR GREASE COLLECTION KIT PNC 922752
- Water inlet pressure reducer PNC 922773
- - NOT TRANSLATED - PNC 922774
- Non-stick universal pan, GN 1/1, H=20mm PNC 925000
- Non-stick universal pan, GN 1/ 1, H=40mm PNC 925001
- Non-stick universal pan, GN 1/1, H=60mm PNC 925002
- Double-face griddle, one side ribbed and one side smooth, GN 1/1 PNC 925003
- Aluminum grill, GN 1/1 PNC 925004
- Frying pan for 8 eggs, pancakes, hamburgers, GN 1/1 PNC 925005
- Flat baking tray with 2 edges, GN 1/1 PNC 925006
- Potato baker for 28 potatoes, GN 1/1 PNC 925008
- Compatibility kit for installation on previous base GN 2/1 PNC 930218

## Front

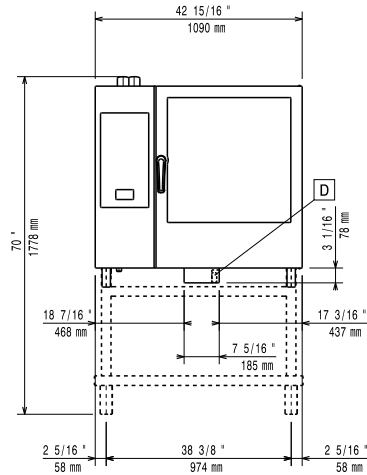

## Side

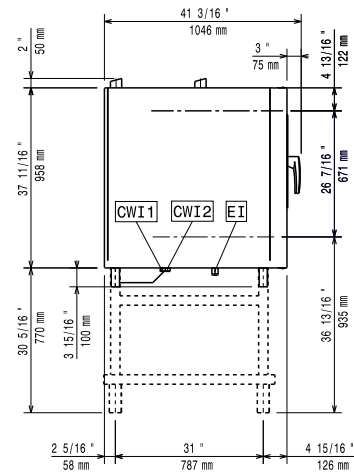

- CWI1 = Cold Water inlet 1
- CWI2 = Cold Water Inlet 2
- EI = Electrical inlet (power)
- D = Drain
- DO = Overflow drain pipe

## Top

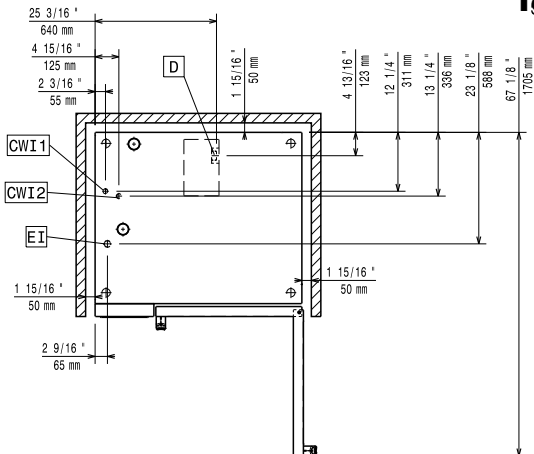

## Electric

<b>Supply voltage:</b>	
218933 (ZCOE102C2S0)	400-430 V/3N ph/50-60 Hz
<b>Electrical power, default:</b>	35.4 kW
<b>Electrical power max.:</b>	36.9 kW
<b>Circuit breaker required</b>	

## Water:

<b>Water inlet "FCW" connection:</b>	3/4"
<b>Pressure, bar min/max:</b>	1-4.5 bar
<b>Drain "D":</b>	50mm
<b>Max inlet water supply temperature:</b>	30 °C
<b>Chlorides:</b>	<10 ppm
<b>Conductivity:</b>	>285 µS/cm

*Electrolux recommends the use of treated water, based on testing of specific water conditions.*  
Please refer to user manual for detailed water quality information.

## Installation:

<b>Clearance:</b>	Clearance: 5 cm rear and right hand sides.
<b>Suggested clearance for service access:</b>	50 cm left hand side.

## Capacity:

<b>GN:</b>	10 - 2/1 Gastronorm
<b>Max load capacity:</b>	100 kg

## Key Information:

<b>Door hinges:</b>	Right Side
<b>External dimensions, Width:</b>	1090 mm
<b>External dimensions, Height:</b>	1058 mm
<b>External dimensions, Depth:</b>	971 mm
<b>Weight:</b>	167.5 kg
<b>Net weight:</b>	167.5 kg
<b>Shipping weight:</b>	195.5 kg
<b>Shipping volume:</b>	1.58 m <sup>3</sup>