

Magistar Combi DS Electric Combi Oven 10GN2/1

ITEM # _____

MODEL # _____

NAME # _____

SIS # _____

AIA # _____



218833 (ZCOE102B2S0)

Magistar Combi DS combi boiler oven with digital control, 10x2/1GN, electric, programmable, automatic cleaning, boiler in AISI304

Short Form Specification

Item No. _____

Combi oven with high resolution full touch screen interface, multilanguage

- Built-in steam generator with real humidity control based upon Lambda Sensor
- AirFlow air distribution system to achieve maximum performance with 7 fan speed levels
- HP Automatic Cleaning: Automatic and built-in self cleaning system with integrated descale of the steam generator. 5 automatic cycles (soft, medium, strong, extra strong, rinse-only) and economizer functions to save energy, water, detergent and rinse aid
- Cooking modes: Automatic (9 food families with 100+ different pre-installed variants); Programs (a maximum of 1000 recipes can be stored and organized in 16 different categories); Manual (steam, combi and convection cycles); Specialistic Cycles (regeneration, Low Temperature Cooking, proving, EcoDelta, Sous-Vide, Static-Combi, Pasteurization of pasta, dehydration, Food Safe Control and Advanced Food Safe Control)
- Special functions: MultiTimer cooking, Cooking Optimizer to cut running costs, Make-it-Mine to customize interface, SoloMio to customize homepage, agenda Calendar, automatic backup mode to avoid downtime
- USB port to download HACCP data, programs and settings. Connectivity ready
- 6-point multi sensor core temperature probe
- Double glass door with LED lights
- Stainless steel construction throughout
- Supplied with n.1 tray rack 2/1 GN, 67 mm pitch.

Main Features

- Digital interface with LED backlight buttons with guided selection.
- Built-in steam generator for highly precise humidity and temperature control according to the chosen settings.
- Real humidity control based upon Lambda Sensor to automatically recognize quantity and size of food for consistent quality results.
- Dry, hot convection cycle (25 °C - 300 °C): ideal for low humidity cooking.
- Combination cycle (25 °C - 300 °C): combining convected heat and steam to obtain humidity controlled cooking environment, accelerating the cooking process and reducing weight loss.
- Low temperature Steam cycle (25 °C - 99 °C): ideal for sous-vide, re-thermalization and delicate cooking. Steam cycle (100 °C): seafood and vegetables. High temperature steam (25 °C - 130 °C).
- EcoDelta cooking: cooking with food probe maintaining preset temperature difference between the core of the food and the cooking chamber.
- Pre-set program for Regeneration, ideal for banqueting on plate or rethermalizing on tray.
- Programs mode: a maximum of 100 recipes can be stored in the oven's memory, to recreate the exact same recipe at any time. 4-step cooking programs also available.
- AirFlow air distribution system to achieve maximum performance in chilling/heating evenness and temperature control thanks to a special design of the chamber combined with high precision variable speed fan.
- Fan with 5 speed levels from 300 to 1500 RPM and reverse rotation for optimal evenness. Fan stops in less than 5 seconds when door is opened.
- Single sensor core temperature probe included.
- Automatic fast cool down and pre-heat function.
- Reduced power function for customized slow cooking cycles.
- HP Automatic Cleaning: Automatic and built-in self cleaning system with integrated descale of the steam generator. 5 automatic cycles (soft, medium, strong, extra strong, rinse-only).
- Grease Collector: predisposed for integrated grease drain and collection for safer operation (dedicated base as optional accessory).
- USB port to download HACCP data, share cooking programs and configurations. USB port also allows to plug-in sous-vide probe (optional accessory).
- Connectivity ready for real time access to connected appliances from remote and HACCP monitoring (requires optional accessory).
- Back-up mode with self-diagnosis is automatically activated if a failure occurs to avoid downtime.
- 2 different chemical options available: solid and liquid (requires optional accessory).
- [NOT TRANSLATED]
- Connectivity ready for real time access to connected appliances from remote and data monitoring (requires optional accessory – contact the Company for more details).

Construction

- Double thermo-glazed door with open frame construction,

APPROVAL: _____

for cool outside door panel. Swing hinged easy-release inner glass on door for easy cleaning.

- Seamless hygienic internal chamber with all rounded corners for easy cleaning.
- 304 AISI stainless steel construction throughout.
- Front access to control board for easy service.
- IPX 5 spray water protection certification for easy cleaning.
- Supplied with n.1 tray rack 2/1 GN, 67 mm pitch.

Optional Accessories

- Water softener with cartridge and flow meter (high steam usage) PNC 920003
- Water softener with salt for ovens with automatic regeneration of resin PNC 921305
- Resin sanitizer for water softener (921305) PNC 921306
- Wheel kit for 6 & 10 GN 1/1 and 2/1 GN oven base (not for the disassembled one) PNC 922003
- Pair of AISI 304 stainless steel grids, GN 1/1 PNC 922017
- Pair of grids for whole chicken (8 per grid - 1,2kg each), GN 1/1 PNC 922036
- AISI 304 stainless steel grid, GN 1/1 PNC 922062
- AISI 304 stainless steel grid, GN 2/1 PNC 922076
- External side spray unit (needs to be mounted outside and includes support to be mounted on the oven) PNC 922171
- Pair of AISI 304 stainless steel grids, GN 2/1 PNC 922175
- Baking tray for 5 baguettes in perforated aluminum with silicon coating, 400x600x38mm PNC 922189
- Baking tray with 4 edges in perforated aluminum, 400x600x20mm PNC 922190
- Baking tray with 4 edges in aluminum, 400x600x20mm PNC 922191
- Pair of frying baskets PNC 922239
- AISI 304 stainless steel bakery/pastry grid 400x600mm PNC 922264
- Double-step door opening kit PNC 922265
- Grid for whole chicken (8 per grid - 1,2kg each), GN 1/1 PNC 922266
- Kit universal skewer rack and 6 short skewers for Lengthwise GN 2/1 and Crosswise ovens PNC 922325
- Universal skewer rack PNC 922326
- 6 short skewers PNC 922328
- Water nanofilter for 10 GN 2/1 & 20 GN 1/1 & 2/1 ovens PNC 922344
- External reverse osmosis filter for ovens 10 GN 2/1 & 20 GN 1/1 & 2/1 ovens PNC 922345
- Multipurpose hook PNC 922348
- 4 flanged feet for 6 & 10 GN, 2", 100-130mm PNC 922351
- Grease collection tray, GN 2/1, H=60 mm PNC 922357
- Grid for whole duck (8 per grid - 1,8kg each), GN 1/1 PNC 922362
- Thermal cover for 10 GN 2/1 oven and blast chiller freezer PNC 922366
- Tray support for 6 & 10 GN 2/1 disassembled open base PNC 922384
- Wall mounted detergent tank holder PNC 922386
- - NOT TRANSLATED - PNC 922390
- Tray rack with wheels 10 GN 2/1, 65mm pitch (std) PNC 922603
- Tray rack with wheels, 8 GN 2/1, 80mm pitch PNC 922604

- Slide-in rack with handle for 6 & 10 GN 2/1 oven PNC 922605
- Bakery/pastry tray rack with wheels 400x600mm for 10 GN 2/1 oven and blast chiller freezer, 80mm pitch (8 runners) PNC 922609
- Open base with tray support for 6 & 10 GN 2/1 oven PNC 922613
- External connection kit for detergent and rinse aid PNC 922618
- Stacking kit for electric 6 GN 2/1 oven placed on electric 10 GN 2/1 oven PNC 922621
- Trolley for slide-in rack for 6 & 10 GN 2/1 oven and blast chiller freezer PNC 922627
- Trolley for mobile rack for 6 GN 2/1 on 6 or 10 GN 2/1 ovens PNC 922631
- Stainless steel drain kit for 6 & 10 GN oven, dia=50mm PNC 922636
- Plastic drain kit for 6 & 10 GN oven, dia=50mm PNC 922637
- Trolley with 2 tanks for grease collection PNC 922638
- Grease collection kit for open base (2 tanks, open/close device and drain) PNC 922639
- Banquet rack with wheels holding 51 plates for 10 GN 2/1 oven and blast chiller freezer, 75mm pitch PNC 922650
- Dehydration tray, GN 1/1, H=20mm PNC 922651
- Flat dehydration tray, GN 1/1 PNC 922652
- Open base for 6 & 10 GN 2/1 oven, disassembled PNC 922654
- Heat shield for 10 GN 2/1 oven PNC 922664
- Heat shield-stacked for ovens 6 GN 2/1 on 10 GN 2/1 PNC 922667
- Kit to fix oven to the wall PNC 922687
- 4 high adjustable feet for 6 & 10 GN ovens, 100-115MM PNC 922688
- Tray support for 6 & 10 GN 2/1 open base PNC 922692
- Wifi board (NIU) PNC 922695
- - NOT TRANSLATED - PNC 922696
- Detergent tank holder for open base PNC 922699
- Mesh grilling grid PNC 922713
- Probe holder for liquids PNC 922714
- Odourless hood with fan for 6 & 10 GN 2/1 electric ovens PNC 922719
- Condensation hood with fan for 6 & 10 GN 2/1 electric oven PNC 922724
- 4 high adjustable feet for 6 & 10 GN ovens, 230-290mm PNC 922745
- Tray for traditional static cooking, H=100mm PNC 922746
- Double-face griddle, one side ribbed and one side smooth, 400x600mm PNC 922747
- TROLLEY FOR GREASE COLLECTION KIT PNC 922752
- Water inlet pressure reducer PNC 922773
- - NOT TRANSLATED - PNC 922774
- Non-stick universal pan, GN 1/1, H=20mm PNC 925000
- Non-stick universal pan, GN 1/1, H=40mm PNC 925001
- Non-stick universal pan, GN 1/1, H=60mm PNC 925002
- Double-face griddle, one side ribbed and one side smooth, GN 1/1 PNC 925003
- Aluminum grill, GN 1/1 PNC 925004
- Frying pan for 8 eggs, pancakes, hamburgers, GN 1/1 PNC 925005
- Flat baking tray with 2 edges, GN 1/1 PNC 925006
- Potato baker for 28 potatoes, GN 1/1 PNC 925008



Magistar Combi DS Electric Combi Oven 10GN2/1

- Compatibility kit for installation on previous base GN 2/1 PNC 930218



**Magistar Combi DS
Electric Combi Oven 10GN2/1**

The company reserves the right to make modifications to the products without prior notice. All information correct at time of printing.

2020.12.10

Front

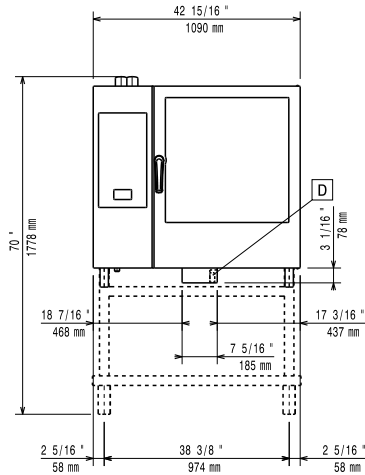

Side

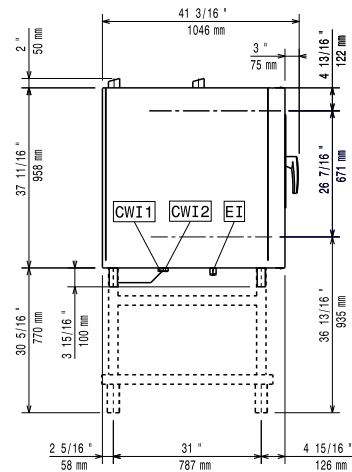

- CWI1 = Cold Water inlet 1
- CWI2 = Cold Water Inlet 2
- EI = Electrical inlet (power)
- D = Drain
- DO = Overflow drain pipe

Top

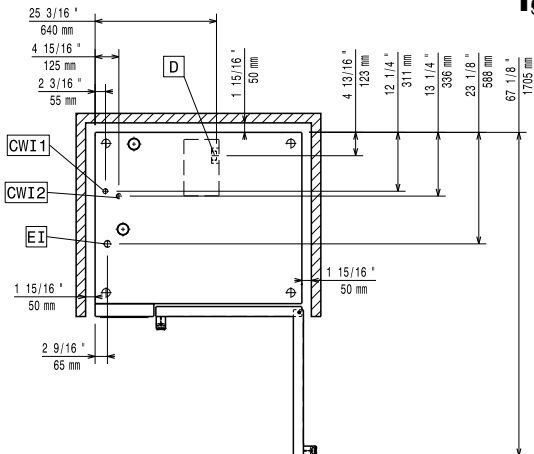

Electric

Supply voltage:	
218833 (ZCOE102B2S0)	400-430 V/3N ph/50-60 Hz
Electrical power, default:	37.4 kW
Electrical power max.:	39 kW
Circuit breaker required	

Water:

Water inlet "FCW" connection:	3/4"
Pressure, bar min/max:	1-4.5 bar
Drain "D":	50mm
Max inlet water supply temperature:	30 °C
Chlorides:	<17 ppm
Conductivity:	>285 µS/cm

Electrolux recommends the use of treated water, based on testing of specific water conditions.
Please refer to user manual for detailed water quality information.

Installation:

Clearance:	Clearance: 5 cm rear and right hand sides.
Suggested clearance for service access:	50 cm left hand side.

Capacity:

GN:	10 - 2/1 Gastronorm
Max load capacity:	100 kg

Key Information:

Door hinges:	Right Side
External dimensions, Width:	1090 mm
External dimensions, Height:	1058 mm
External dimensions, Depth:	971 mm
Weight:	181.5 kg
Net weight:	181.5 kg
Shipping weight:	208.5 kg
Shipping volume:	1.58 m ³